

Automatic Three-Phase Load Controller with Timer and Contactor for Energy Conservation

Mr. Dr Samala Nagaraju, J. Sravanthi, Abdul Shaizan, M.Shivashankar, B.Sai Pranay, M.Harishwar, B.Vivek, M.Manoj Kumr, J.Danush Kumar, D.Ashish Kumar, D.Aditya, C.Rukmini, G.Anusha, P.Ashwitha, L.Harshitha, M.Akshaya

¹I/c Head of Department EEE, Government Polytechnic Bellampalli, Mancherial, Telangana, India

²Lecturer of Department EEE, Government Polytechnic Bellampalli, Mancherial, Telangana, India

³⁻¹⁴Students, Government Polytechnic Bellampalli, Mancherial, Telangana, India

Corresponding Author: Dr Samala Nagaraju

ABTRACT

The increasing demand for reliable and efficient power management in industrial and commercial environments has made controlled operation of three-phase loads essential. Conventional manual switching methods often lead to operational inefficiencies, inconsistent load management, and increased risk of equipment damage due to improper handling. The absence of structured timing control can result in unnecessary energy consumption, reduced equipment lifespan, and safety concerns in high-power applications.

This project, titled Automatic Three-Phase Load Control with Timer and Contactor for Energy Conservation, presents a practical and reliable solution for controlled switching of three-phase electrical loads. The proposed system integrates an electromagnetic contactor, a programmable timer relay, and a manual override switch to enable both automated and manual control of industrial loads. The timer facilitates scheduled operation by energizing the contactor coil after a preset delay, while the manual switch ensures operational flexibility during maintenance, testing, or emergency conditions.

Date of Submission: 27-04-2026

Date of acceptance: 06-05-2026

I. INTRODUCTION

1.1 Background to Study

Electrical energy plays a vital role in the development of modern society, as it is widely used in residential, commercial, and industrial sectors for various applications such as lighting, heating, cooling, and operation of machinery. With the rapid growth in population and industrialization, the demand for electrical energy has increased significantly. However, the available resources for power generation are limited, and excessive consumption leads to increased pressure on power systems as well as environmental concerns. Therefore, efficient utilization and conservation of electrical energy have become essential.

In many practical situations, electrical loads are controlled manually, which often leads to improper usage. Devices such as lights, fans, and other equipment are sometimes left ON even when not required, mainly due to human negligence or lack of supervision. This results in unnecessary energy consumption, increased electricity costs, and reduced efficiency of the system. Such issues are commonly observed in places where multiple users are involved, and there is no fixed responsibility for switching OFF electrical loads. To overcome these problems, automation in electrical systems has become increasingly important. Automatic control systems help in operating electrical loads based on predefined conditions, thereby reducing dependency on human intervention. Among various automation techniques, time-based control is one of the simplest and most effective methods. It allows electrical devices to be operated according to a fixed schedule, ensuring that they function only during required time. The use of devices such as digital timers and contactors enables the development of reliable automatic load control systems. These systems can control high-power loads with the help of low-power control signals, ensuring both safety and efficiency. By integrating such components, it is possible to design systems that not only reduce energy wastage but also improve the overall performance and lifespan of electrical equipment.

Thus, the study of automatic load control systems is important for understanding how electrical energy can be managed efficiently. This project focuses on implementing a practical solution using basic electrical components to achieve energy conservation and improve system reliability through automation.

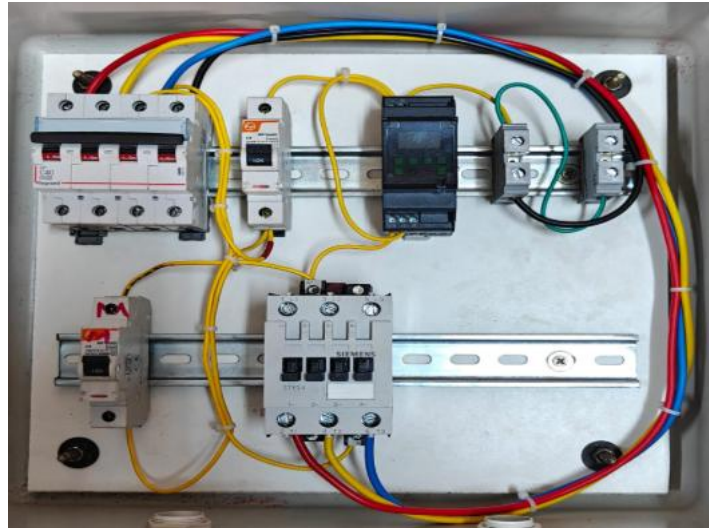

Fig 1.1 Image of the Circuit

1.2 Statement of the Research

In many electrical installations, the control of loads is still carried out manually, which often leads to inefficient usage of electrical energy. Due to the absence of a proper control mechanism, devices such as lighting systems, fans, and other electrical equipment may remain in operation even when they are not required. This unnecessary usage mainly occurs due to human negligence, lack of supervision, or irregular operating schedules. As a result, there is a significant amount of energy wastage, leading to increased electricity consumption and higher operational costs.

Another major issue with manual control is the inconsistency in operation. Different individuals may operate the system at different times, which leads to irregular usage patterns and affects the overall efficiency of the electrical system.

To address these issues, it is necessary to develop a system that can automatically control the switching of loads without relying on human intervention. A time-based automatic load control system provides an effective solution by operating loads according to predefined schedules. Such a system ensures that electrical devices are used only when required, thereby minimizing wastage and improving efficiency.

Hence, the main problem identified in this project is the lack of an automatic and reliable system for controlling electrical loads, which leads to energy wastage, increased costs, and reduced system efficiency. The project aims to overcome these problems by implementing a timer-based automatic load controller using a contactor

1.3 Significance of Research

This project is significant as it provides a practical and effective solution for energy conservation in electrical systems. In many places, electrical loads are often left ON unnecessarily due to human negligence, which leads to energy wastage and increased electricity consumption. By implementing an automatic load control system, this issue can be effectively minimized.

Electrical energy conservation is essential for ensuring efficient utilization of power and reducing unnecessary wastage. With the increasing demand for electricity, conserving energy helps in reducing the load on power generation systems and minimizes environmental impact. Uncontrolled usage of electrical devices not only increases electricity bills but also leads to depletion of natural resources used for power generation.

The proposed system eliminates human error by automatically controlling the operation of loads based on preset timings. This ensures that electrical devices operate only during required hours, thereby reducing unnecessary power consumption. In addition, the system improves the lifespan of electrical equipment by avoiding continuous or excessive operation.

Another important advantage of this project is its simplicity and cost-effectiveness. The system is designed using easily available components such as timers, contactors, and MCBs, making it economical and easy to implement. It does not require complex programming or advanced technical knowledge, which makes it suitable for various applications. Furthermore, the inclusion of a manual override feature provides flexibility in operation, allowing users to control the system when required. Overall, this project contributes to efficient energy management, reduces operational costs, and promotes sustainable use of electrical energy.

1.4 Introduction of the Project

The project titled 3 Phase Automatic Load Controller with Timer and Contactor for Energy Conservation is designed to automatically control electrical loads using a time-based mechanism. The system aims to reduce energy wastage and improve efficiency by ensuring that electrical devices operate only during required time periods without the need for manual switching.

In this system, a digital timer is used as the main control unit. The timer is programmed with specific ON and OFF timings according to the operational requirements. Based on these settings, the timer sends control signals to the contactor coil. The contactor, which is an electrically operated switching device, controls the three-phase power supply to the load. When the timer activates the contactor, the load is switched ON, and when the timer deactivates it, the load is switched OFF.

The system consists of both power and control circuits. The power circuit includes the three-phase supply, MCB, contactor, and load, while the control circuit includes the timer, control supply, and manual override switch. The MCBs are used to protect both circuits from overcurrent and short circuit conditions, ensuring safe and reliable operation. A manual override switch is also incorporated in the system to provide flexibility. This allows the user to operate the load manually when required, especially outside the program schedule. This feature ensures that the system is not completely dependent on automation and can be used according to user requirements. The project is designed using simple and easily available components, making it economical and easy to implement. It does not require complex programming or advanced control systems, which makes it suitable for a wide range of applications. The system is reliable, efficient, and effective in reducing unnecessary power consumption.

Overall, this project demonstrates a practical approach to energy conservation by combining automation with electrical control systems. It highlights the importance of efficient load management and provides a simple solution to reduce energy wastage in various environments.

II. LITERATURE REVIEW

2.1 Literature Review

Energy conservation has become a major focus in electrical engineering due to the increasing demand for power and the need to reduce wastage. Various methods and systems have been developed over time to control electrical loads efficiently and minimize unnecessary consumption.

One of the simplest and most widely used methods is the use of timer-based control systems. These systems operate by switching electrical loads ON and OFF at predefined times. Mechanical timers were initially used, but they lacked accuracy and flexibility. With technological advancements, digital timers have replaced mechanical timers, offering higher precision, programmability, and reliability.

Another important component in load control systems is the contactor, which is an electrically operated switch used for controlling high-power circuits. Contactors are widely used in industrial and commercial applications because they can handle large currents and provide safe switching operations. They are often used along with control devices like timers, relays, and programmable controllers. In modern systems, Programmable Logic Controllers (PLCs) and microcontroller-based automation are also used for load control. These systems offer advanced features such as remote monitoring, complex scheduling, and integration with smart systems. However, they are more expensive and require programming knowledge, making them less suitable for simple applications.

Research and practical implementations have shown that timer-based automatic load controllers are highly effective in reducing energy wastage caused by human error. These systems are economical, easy to install, and require minimal maintenance. They are particularly useful in places where loads need to operate on fixed schedules. The present project is based on this concept and uses a digital timer along with a contactor to achieve automatic control of three-phase loads in an efficient and reliable manner.

2.2 Scope and Objectives

2.2.1 Scope of the Project

The scope of this project includes the design and implementation of a three-phase automatic load control system using a timer and contactor. The system is intended to control electrical loads based on predefined time schedules without requiring continuous human supervision.

This project can be applied in various areas where efficient and automated control of electrical loads is required. In educational institutions, it can be used to manage lighting, fans, and other equipment according to fixed schedules, reducing unnecessary power consumption. In offices and commercial buildings, the system helps automate daily operations by controlling electrical devices based on working hours, thereby improving energy efficiency and minimizing manual effort. Similarly, in libraries and public facilities, it ensures that electrical loads operate only when needed, maintaining convenience while conserving energy. In industrial setups and workshops, the system can be used to regulate machinery and equipment timings, enhancing productivity, ensuring proper utilization of resources, and reducing operational costs.

The system is suitable for controlling loads like lighting, fans, and other electrical equipment that operate on fixed timings.

It is designed to be simple, cost-effective, and easy to maintain.

However, the project is limited to time-based control only and does not include advanced features such as remote control, sensor-based automation, or real-time monitoring.

2.2.2. Objectives of the Project

The main objective of this project is to design and implement a reliable system that can automatically control electrical loads using a timer and contactor. The system aims to reduce human intervention and improve the efficiency of electrical energy usage. One of the primary objectives is to automate the operation of three-phase loads based on preset time schedules. By doing so, the system ensures that electrical devices are switched ON and OFF at the required time without the need for manual operation. This helps in maintaining consistency and accuracy in load control.

Another important objective is to reduce energy wastage caused by human error. In many cases, loads are left ON unnecessarily due to negligence. This project eliminates such issues by ensuring that loads are operated only during required periods, thereby conserving electrical energy.

The project also aims to develop a simple and cost-effective solution using easily available components such as a digital timer, contactor, and MCBs. The simplicity of the design ensures that the system can be easily installed, operated, and maintained without requiring advanced technical knowledge. Ensuring safety and protection is another key objective. The use of MCBs in the system helps protect against overcurrent and short circuit conditions, thereby preventing damage to equipment and ensuring safe operation of the system.

The project also focuses on providing flexibility in operation through the inclusion of a manual override switch. This allows the user to operate the load manually when required, especially outside the program time schedule.

Additionally, the project aims to improve the lifespan of electrical equipment by preventing unnecessary continuous operation. Controlled usage reduces wear and tear on devices, thereby increasing their durability and reliability.

Overall, the objective of this project is to create an efficient, reliable, and user-friendly system that promotes energy conservation and effective management of electrical loads.

III. METHODOLOGY

3.1 Working Flowchart

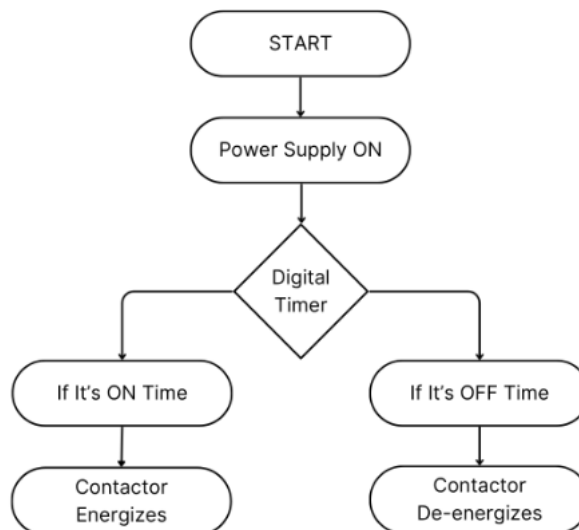

Fig 3.1: Working Flowchart

The flowchart represents the automatic operation of the load control system using a digital timer and contactor. The process begins when the power supply is switched ON, after which the digital timer starts functioning. The timer continuously checks the current time and compares it with the preset ON and OFF timings. When the set ON time is reached, the timer sends a signal to the contactor coil, causing it to energize and supply power to the load. Similarly, when the OFF time is reached, the timer stops the signal, and the contactor de-energizes, disconnecting the load. This automatic process ensures that the load operates only during required hours.

It eliminates the need for manual switching and reduces energy wastage. The system continues this cycle daily based on the program schedule.

3.2 Hardware Components

The hardware section of this project consists of essential electrical devices required for controlling, protecting, and operating the system efficiently. These components work together to ensure proper switching, safety, and reliable performance of the load control system.

3.2.1 Contactor

Contactors are preferred over manual switches because they provide safer and more reliable operation, especially in systems where frequent switching is required. They also help in isolating the control circuit from the power circuit, reducing the risk of electrical hazards. In three-phase systems, contactors are commonly used to control the supply to loads by switching all phases simultaneously. In this project, a contactor is used to control the three-phase power supplied to the load based on signals received from the digital timer. This ensures automatic and efficient operation of the system without the need for continuous manual intervention.



Fig 3.2.1: contactor

A contactor is an electrically operated switching device widely used in electrical power systems to control high-power loads. It is designed to handle large currents and voltages, making it suitable for applications involving motors, lighting systems, and other heavy electrical equipment. The main function of a contactor is to open or close an electrical circuit using a low-power control signal. It consists of a coil, contacts, and an enclosure.

Additionally, contactors are durable, have a long operational life, and can be easily integrated with protective devices such as MCBs, making them an essential component in modern electrical control systems.

3.2.2 MCB



Fig 3.2.2: 4-Pole MCB

A Miniature Circuit Breaker (MCB) is an essential protective device used in electrical systems to safeguard circuits from damage caused by overcurrent and short circuit conditions. It is designed to automatically interrupt the flow of current when it exceeds a safe limit, thereby preventing overheating, fire hazards, and damage to electrical equipment. Unlike traditional fuses, which need to be replaced after operation, an MCB can be reset

manually after it trips, making it more convenient and reliable. The working principle of an MCB is based on thermal and magnetic effects.

Under normal operating conditions, the MCB allows current to pass through it without interruption. In case of overload, the thermal mechanism inside the MCB heats up and causes it to trip after a certain time delay. In case of a short circuit, the magnetic mechanism acts instantly and disconnects the circuit immediately. MCBs are available in different types and ratings depending on the application, and in three-phase systems, a 4-pole MCB is commonly used to disconnect all phases and neutral simultaneously.

In this project, MCBs are used to provide protection to both the power circuit and the control circuit. The main 4 pole MCB ensures safety of the three-phase supply, while the single-pole MCB protects the control components such as the timer. Thus, the use of MCBs enhances the overall safety, reliability, and efficiency of the system.

3.2.3 Digital Timer



Fig 3.2.3: GIC Timer

24V digital timer (GIC timer) is used to automatically control the ON and OFF operation of the system. It is programmed with specific timings according to the required schedule. A timer is an important control device used in electrical systems to perform automatic switching operations based on time. It is widely used in industrial and commercial applications where loads need to be controlled according to a fixed schedule. A digital timer, in particular, provides accurate and reliable timing control with easy programming options. It allows the user to set specific ON and OFF timings, ensuring that electrical devices operate only during required periods. The working of a timer is based on an internal electronic circuit that keeps track of time and triggers output signals when the preset conditions are met. In normal operation, the timer continuously compares the current time with the program schedule. When the ON time is reached, it sends a signal to activate the connected device, and when the OFF time is reached, it stops the signal, thereby turning the device OFF. In this project, a GIC digital timer is used to control the operation of the contactor.

The timer receives a control supply and sends signals to the contactor coil, which in turn controls the three-phase load. This eliminates the need for manual switching and ensures that the load operates automatically without human intervention.

The use of a timer improves efficiency, reduces energy wastage, and enhances the reliability of the system.

3.2.4 Manual Override Switch

A manual override switch is an important component in an automatic control system that allows the user to operate the system manually when required. In fully automated systems, devices operate based on preset conditions such as time or sensor input, but there are situations where manual control becomes necessary. The manual override switch provides this flexibility by bypassing the automatic control and directly operating the load. In this project, a single-pole MCB is used as a manual override switch. It allows the user to turn ON the load even outside the program timer schedule, such as during extended working hours or special conditions. When the manual switch is activated, it directly energizes the contactor coil, causing the contactor to close and supply power to the load. When switched OFF, the system returns to automatic mode controlled by the timer.



Fig 3.2.4: Manual Override switch

A single-pole MCB is used as a manual override switch. It allows the user to manually turn ON the load when required, especially outside the timer schedule.

The inclusion of a manual override feature ensures that the system is not completely dependent on automation and can still function as needed under user control. It also improves the practicality and usability of the system in real-world applications. Overall, the manual override switch adds flexibility, convenience, and reliability to the automatic load control system.

3.2.5 Cable

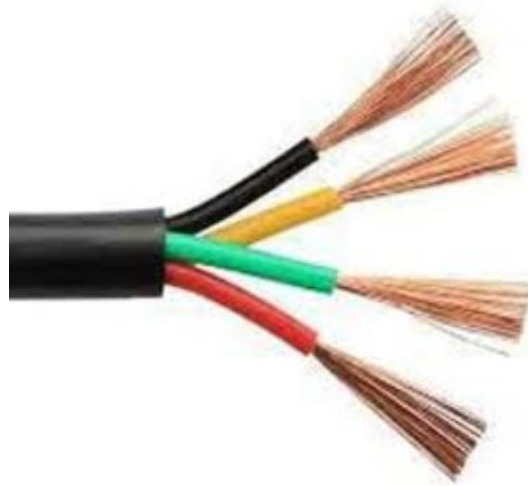

Fig 3.2.5: 4 core cable

The cable is insulated and sheathed properly to provide protection against environmental factors such as moisture, dust, and mechanical damage. This makes it suitable for use in industrial and commercial electrical installations where durability and reliability are important.

The outer sheath also helps in maintaining proper insulation between conductors, preventing short circuits.

3.2.6 Panel Box



Fig 3.2.6: Panel Box

The panel box is an essential component used for housing and protecting all the electrical components of the system. It provides a safe and organized enclosure for devices such as the MCBs, contactor, digital timer, neutral links, and wiring connections. The use of a panel box ensures that all components are properly mounted and secured, reducing the chances of loose connections and mechanical damage.

The panel box is typically made of PVC which provides high mechanical strength and durability. It protects the internal components from external factors such as dust, moisture, accidental contact, and physical impact. This is especially important in practical environments where electrical panels are exposed to different operating conditions. The metal body also helps in providing proper earthing, which enhances safety by preventing electric shocks.

Proper arrangement of components inside the panel box improves the overall appearance and makes maintenance easier. The internal layout is designed in such a way that the power circuit and control circuit are clearly separated, ensuring better understanding and troubleshooting. Adequate spacing is maintained between components to avoid overheating and to allow proper airflow for cooling.

3.2.7 Neutral Links



Fig 3.2.7: Neutral Links

Neutral links are an important part of the electrical control system, used for the proper distribution and connection of the neutral conductor throughout the circuit. In any system that includes control devices such as timers and relays, a stable and continuous neutral connection is essential for accurate and reliable operation. Neutral links provide a common point where multiple neutral wires can be connected securely, ensuring proper circuit completion.

Since electronic devices are sensitive to voltage fluctuations, a proper neutral connection helps in maintaining a stable voltage level and prevents malfunction or irregular operation of the timer. Without a proper neutral link, the system may experience instability, incorrect timing, or failure to operate as intended.

3.4 Working Principle

3.4.1 Block Diagram

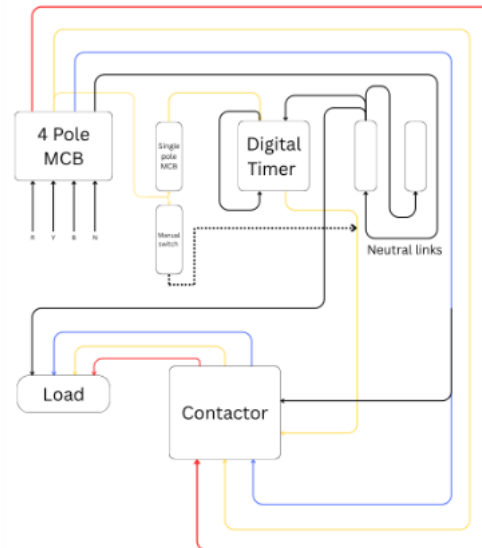

Fig 3.4.1: Block diagram of the Project

The block diagram represents the complete wiring and operational layout of the three-phase automatic load control system using a timer and contactor. The three-phase supply consisting of R, Y, B, and neutral is first given to the 4-pole MCB, which provides protection to the entire system by disconnecting the supply in case of overcurrent or fault conditions. From the MCB, the power lines are connected to the contactor, which acts as the main switching device controlling the supply to the load. The load is connected to the output side of the contactor, and it receives power only when the contactor is energized. For the control circuit, a single-phase supply is taken through a single-pole MCB to protect the control components. This supply is then provided to the digital timer, which is program with specific ON and OFF timings.

The timer sends control signals to the contactor coil, thereby controlling its operation automatically. Neutral links are used to ensure proper and stable neutral connections for the timer and control circuit, preventing fluctuations. A manual override switch is also included in the circuit, which allows the user to operate the contactor directly when required, bypassing the timer control. This feature is useful during special conditions or extended usage requirements.

The diagram clearly shows the integration of power and control circuits, ensuring safe, efficient, and automatic operation of the electrical load while also providing flexibility through manual control.

3.4.2 Power Flowchart

The system can be represented using the following block diagram.

The power flowchart clearly illustrates the path through which electrical energy is delivered from the source to the load in a controlled and protected manner. The three-phase supply enters the system and is first passed through the 4-pole MCB, which acts as the primary protective device. This ensures that any abnormal condition such as overload or short circuit is immediately detected and the supply is disconnected to prevent damage. Once the MCB is in the ON condition, the power is directed towards the contactor, which serves as the main control element in the power circuit.

This arrangement ensures that high-power switching is performed safely and efficiently without exposing the user to direct handling of heavy electrical currents. It also allows centralized control of the entire load through a single switching device.

The flowchart emphasizes the importance of proper sequencing, where protection is ensured first, followed by controlled switching, and finally delivery of power to the load.

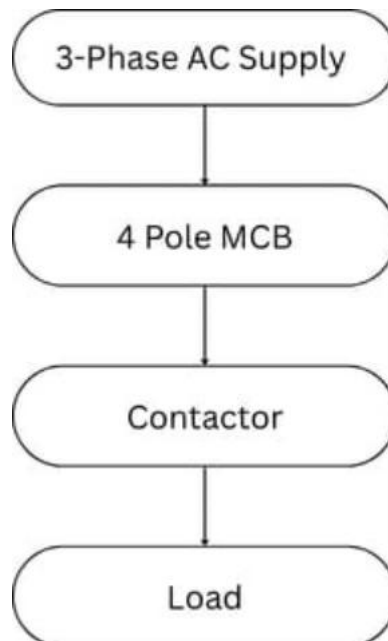

Fig 3.4.2: Power Flowchart

The contactor plays a crucial role in controlling the supply to the load without directly handling the control signals. It acts as an interface between the low-power control circuit and the high-power load circuit. When the contactor is in its normal state, the circuit remains open, and no power is supplied to the load. Only when the contactor coil receives a signal from the control circuit does it close its contacts and complete the circuit, allowing current to flow.

Furthermore, the use of a structured power flow helps in maintaining system stability and simplifies troubleshooting. Any fault in the system can be easily traced by following the power path from the supply to the load. Overall, the power flowchart demonstrates a well-organized and safe method of distributing electrical energy in the system.

3.4.3 Control flowchart

Based on these settings, the timer sends signals to the contactor coil. When the timer activates the coil, the contactor closes and allows power to the load, and when the signal is removed, the contactor opens. This ensures automatic control of the system based on time. This allows the power circuit to supply electricity to the load. When the preset OFF time is reached, the timer stops the signal, de-energizing the contactor coil and opening the contacts, thereby disconnecting the load.

Additionally, a manual override path is provided through a bypass switch, which allows direct energization of the contactor coil when required. Thus, the control flowchart illustrates how the timer and control components work together to achieve automatic and manual operation of the system.

This flowchart shows the control circuit where a single-phase supply is given through a bypass MCB to the digital timer. The timer controls the contactor coil, which in turn operates the main power circuit. The control power flowchart represents the operation of the control circuit using a single-phase supply. A single-phase line is taken through a bypass MCB, which provides protection to the control circuit. This supply is then given to the digital timer, which is program with specific ON and OFF timings.

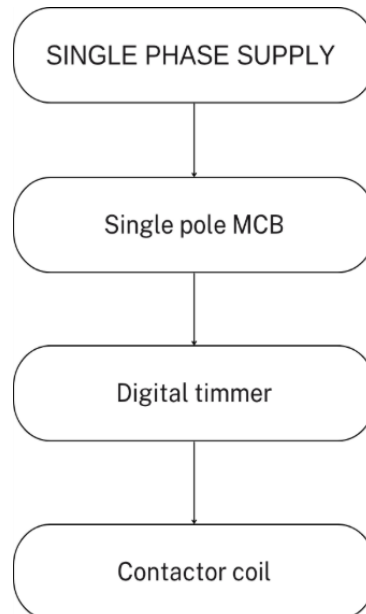

Fig 3.4.3: Control flowchart

3.4.4 Working of the 3-phase Automatic load controller

The working of the three-phase automatic load controller with timer and contactor is based on the coordination between the power circuit and the control circuit. The system is designed to automatically switch electrical loads ON and OFF according to preset timings, thereby reducing human intervention and conserving energy.

Initially, the three-phase supply consisting of R, Y, B, and neutral is given to the 4-pole MCB. The MCB acts as a protective device and ensures that the entire system is safeguarded against overcurrent and short circuit conditions. When the MCB is in ON condition, the supply is allowed to pass through to the rest of the circuit. From the output of the MCB, the three-phase lines are connected to the main terminals of the contactor. The contactor serves as the primary switching device that controls the power flow to the load.

The load is connected to the output side of the contactor. However, the load does not receive power continuously. The supply to the load depends on whether the contactor is energized or de-energized. The energization of the contactor is controlled by the timer through the control circuit.

For the control circuit, a single-phase supply is taken from one of the phases (Y phase) and neutral. This supply is passed through a single-pole MCB, which provides protection specifically to the control components. From this MCB, the supply is given to the digital timer. The timer used in this system is a programmable device that allows the user to set specific ON and OFF timings according to requirements. The digital timer continuously monitors the current time and compares it with the program schedule. When the preset ON time is reached, the timer sends an electrical signal to the contactor coil. This energizes the coil, creating a magnetic field that pulls the contactor contacts together. As a result, the contactor closes, allowing the three-phase supply to pass through to the load, and the load starts operating. Similarly, when the preset OFF time is reached, the timer stops sending the signal to the contactor coil.

This causes the coil to de-energize, and the contactor returns to its normal open position. As a result, the supply to the load is disconnected, and the load stops operating. This automatic switching ensures that the load operates only during required time intervals, thereby eliminating unnecessary energy consumption. Neutral links are provided in the system to ensure proper distribution and stability of the neutral connection. This is important for the correct functioning of the timer and control circuit, as fluctuations in neutral can affect the performance of electronic devices.

In addition to automatic operation, the system also includes a manual override switch. This switch allows the user to operate the load manually when required, especially outside the preset timing schedule. When the manual switch is turned ON, it directly energizes the contactor coil, bypassing the timer control. This provides flexibility in operation and ensures that the system can be used even during special conditions or extended working hours.

Overall, the system operates efficiently by combining automatic time-based control with manual override capability. It ensures safe operation through the use of protective devices like MCBs and provides reliable switching using the contactor. The integration of these components results in an effective solution for reducing energy wastage and improving the efficiency of electrical load management.

IV. RESULT ANALYSIS

The implemented system, 3 Phase Automatic Load Control with Timer and Contactor for Energy Conservation, was tested under practical conditions to evaluate its performance, reliability, and effectiveness in reducing energy wastage.

4.1 Performance of the System

The performance of the implemented system was evaluated under practical operating conditions to verify its effectiveness, reliability, and accuracy in controlling the load. The system showed satisfactory performance in all aspects and operated according to the predefined time settings without any major issues.

When the power supply was switched ON, the digital timer initialized properly and began monitoring the program schedule. The timer responded accurately to the preset ON and OFF timings, and the contactor operated accordingly. At the programmed-ON time, the contactor energized immediately and allowed the three-phase supply to reach the load. Similarly, at the program OFF time, the contactor de-energized and disconnected the supply without delay. This ensured proper and timely operation of the load.

Overall, the system demonstrated reliable, efficient, and accurate performance. It successfully achieved automatic control of the load while ensuring safety and ease of operation. The results confirm that the system is suitable for practical applications where time-based control and energy conservation are required.

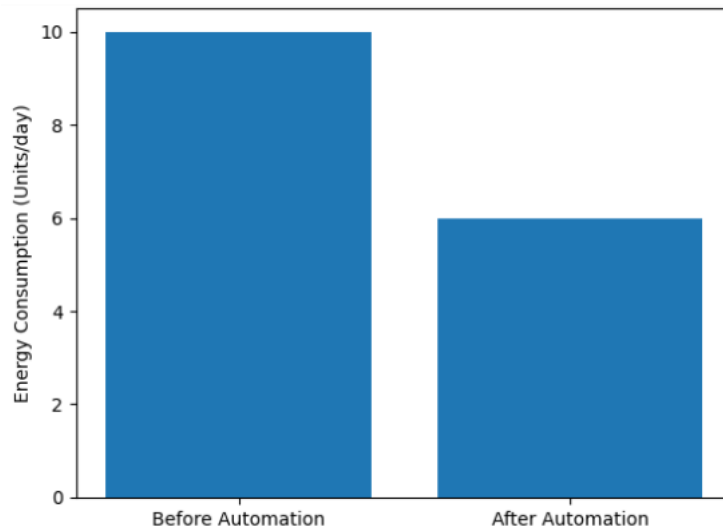

Fig 4.1: Graph of energy consumption before and after Automation

The switching operation of the contactor was smooth and consistent throughout the testing period. No abnormal noise, sparking, or delay was observed during switching. The contactor was able to handle the load effectively without overheating, indicating that it was suitable for the given application. The system also maintained stable performance even during continuous operation.

The digital timer performed reliably and maintained accurate time tracking. There were no noticeable fluctuations or errors in timing, which ensured precise control of the load. The use of neutral links contributed to the stable operation of the timer by providing a proper neutral connection.

The manual override switch also functioned effectively. When activated, it allowed the load to operate independently of the timer, and when switched OFF, the system returned to automatic mode without any disturbance. This provided flexibility and ensured uninterrupted operation when required.

The protective devices, including the MCBs, worked efficiently by safeguarding the system from potential faults. In case of abnormal conditions, the MCBs were capable of interrupting the circuit, thereby preventing damage to the components.

4.1.1 Energy Conservation Analysis

The main objective of this project is to reduce unnecessary energy consumption by automating the control of electrical loads. The energy conservation capability of the system was analyzed by comparing the operation of loads before and after the implementation of the automatic load controller. Before the implementation of the system, electrical loads were operated manually. In many cases, loads such as lights and fans were left ON even after the required working hours due to human negligence or oversight.

This resulted in unnecessary energy consumption, increased electricity bills, and inefficient utilization

of electrical resources. Since there was no automatic mechanism to switch OFF the loads, energy wastage was a common issue. After the implementation of the automatic load control system, the operation of loads became fully dependent on the preset timings in the digital timer.

The system ensured that the loads were switched ON and OFF exactly according to the required schedule. As a result, there was no possibility of loads being left ON unintentionally. This eliminated human error completely and ensured that electrical energy was used only when required.

The reduction in operating hours of the load directly contributed to energy savings. Since the loads were automatically switched OFF after the preset time, unnecessary running time was minimized. This led to a significant decrease in overall power consumption. The system also ensured consistent operation every day without variation, which further improved efficiency.

In addition to reducing energy wastage, the system also helps in lowering operational costs. By minimizing unnecessary power usage, the electricity consumption is reduced, resulting in cost savings over time. Furthermore, controlled operation of electrical devices prevents excessive usage, thereby increasing their lifespan and reducing maintenance requirements. The results clearly indicate that the automatic load controller is effective in achieving energy conservation. The system provides a simple yet efficient solution to manage electrical loads and ensures optimal utilization of energy. Thus, the project successfully meets its objective of reducing energy wastage and promoting efficient power management.

4.1.2 Reliability & Safety

The system proved to be highly reliable during continuous operation, maintaining consistent performance throughout the testing period. The contactor handled the electrical load efficiently without any signs of overheating, indicating its suitability for sustained use. The digital timer maintained accurate timing without any fluctuations, ensuring precise control of load operation according to the set schedule.

The system is also designed with multiple safety measures to protect both the equipment and the users. The inclusion of MCBs in both the power circuit and control circuit ensures protection against overcurrent and short circuit conditions. In case of any fault, the MCB automatically trips and disconnects the supply, thereby preventing damage to components and reducing the risk of electrical hazards such as fire or overheating.

Proper wiring practices and the use of appropriate cable sizes further enhance the safety of the system. The use of neutral links ensures stable operation of the control circuit and prevents fluctuations that may affect the timer's performance. All components are enclosed within a metal panel box, which provides mechanical protection and prevents accidental contact with live parts.

The manual override feature is designed in such a way that it allows safe operation without disturbing the overall system. It provides flexibility while maintaining control over the circuit. Additionally, proper insulation and secure connections reduce the chances of leakage current and electrical faults. Overall, the system is both reliable and safe, as it combines accurate control, protective devices, and proper design practices. It ensures efficient operation of electrical loads while minimizing risks and maintaining a high level of operational safety.

4.1.3 Advantages Observed

The implementation of the three-phase automatic load controller provided several practical advantages during operation and testing. One of the major advantages observed is the complete elimination of human error in switching operations. Since the system operates based on preset timings, there is no possibility of loads being left ON unintentionally, which ensures efficient energy usage.

Another important advantage is energy conservation. The system allows loads to operate only during required time periods, thereby reducing unnecessary power consumption. This directly contributes to lower electricity usage and improved efficiency of the overall system. The automatic control also ensures consistency in operation every day without variation.

The system also offers ease of operation, as once the timer is programmed, no further manual intervention is required. This makes it highly convenient, especially in applications where regular monitoring is not possible. Additionally, the manual override feature provides flexibility, allowing the user to operate the system when needed outside the programmed schedule.

Safety and protection are another key advantage. The use of MCBs ensures that the system is protected from overcurrent and short circuit conditions. This prevents damage to electrical components and enhances the overall reliability of the system. Proper wiring and use of suitable components also contribute to safe operation.

The project is also cost-effective and simple in design, as it uses basic and easily available components. It does not require complex programming or advanced technology, making it easy to install and maintain. Furthermore, the system helps in increasing the lifespan of electrical equipment by preventing unnecessary continuous operation.

4.1.4 Limitations

Although the system performs effectively for automatic load control, certain limitations were observed during its design and operation. One of the main limitations is that the system operates based only on preset timings. It does not consider real-time conditions such as occupancy or actual requirement of the load. As a result, the load may still operate during scheduled time even if it is not needed, which can lead to partial energy wastage. Another limitation is the lack of flexibility in basic timer settings. The digital timer allows fixed scheduling, but frequent changes in timing require manual reprogramming. This can be inconvenient in situations where operating schedules change regularly.

The system also depends on a continuous power supply for proper functioning of the control circuit. In case of power failure, the operation is interrupted, and although the timer may retain settings, the system cannot function until power is restored. Since the system uses a mechanical contactor, there is a possibility of wear and tear over time due to frequent switching operations. This may require periodic maintenance or replacement to ensure reliable performance. Another limitation is that the system does not provide remote monitoring or control. All operations, including programming and manual override, must be performed directly at the panel, which may not be convenient for large or remote installations.

Additionally, the system is designed for basic automation only and does not include advanced features such as load sensing, fault indication display, or energy monitoring. This limits its capability compared to modern smart control systems.

Overall, while the system is simple, reliable, and effective for basic applications, it has certain limitations that can be improved through further development and integration of advanced technologies.

4.1.5 Overall Result

The project was successfully implemented and tested. The system achieved its main objective of automatic load control and energy conservation. The results clearly indicate that the system is effective, reliable, and suitable for practical applications where electrical loads need to be controlled based on fixed time schedules.

V. CONCLUSION

The project titled “3 Phase Automatic Load Controller with Timer and Contactor for Energy Conservation” has been successfully designed, implemented, and tested. The system effectively achieves automatic control of electrical loads based on preset timings, thereby reducing the need for manual intervention. The use of a digital timer ensures accurate and reliable time-based operation, while the contactor enables safe switching of high-power three-phase loads. The coordination between the control circuit and power circuit allows smooth and efficient functioning of the system. The inclusion of protective devices such as MCBs enhances the safety of the overall setup.

Overall, the project successfully meets its objectives of automation, energy conservation, and efficient load management. It provides a dependable solution for controlling electrical loads and can be further enhanced with advanced technologies in future applications.

VI. FUTURE RESEARCH & DEVELOPMENT

6.2 Development

The current system can be further developed by incorporating additional features and improvements to enhance its performance, usability, and application range. One of the key developments can be the addition of a display and user interface system. A digital display can show important information such as current time, ON/OFF status, and programmed schedules. This would make it easier for users to understand and monitor the system operation. Another significant development is the ability to control multiple loads independently. By using multiple timers or advanced controllers, different loads can be operated at different timings according to their specific requirements. This would make the system more flexible and suitable for larger installations where different sections need separate control.

The system can also be improved by adding a backup power supply for the timer and control circuit. This ensures that the programmed settings are retained even during power failures, and the system resumes normal operation once the power is restored. This increases the reliability and continuity of the system. Further development can include replacing mechanical contactors with solid-state switching devices such as relays or thyristors. These devices offer faster switching, reduced wear and tear, and longer operational life. They also minimize noise and sparking, improving the overall efficiency and safety of the system. Another important enhancement is the inclusion of remote control and monitoring features. This can be achieved through wireless communication technologies, allowing users to operate and monitor the system from a distance. This is especially useful in large facilities where manual access to the control panel may be difficult.

Finally, the system can be developed into a fully automated energy management system by combining

timer-based control, sensor input, and smart technologies. Such a system would not only reduce energy wastage but also optimize energy usage based on real-time requirements. Overall, these developments can significantly improve the functionality, reliability, and efficiency of the system, making it more suitable for modern applications and future technological advancement.

REFERENCES

- [1]. B.L. Theraja and A.K. Theraja, *A Textbook of Electrical Technology*, S. Chand Publications
- [2]. V.K. Mehta and Rohit Mehta, *Principles of Power System*, S. Chand Publications
- [3]. GIC (General Industrial Controls), Digital Timer User Manual
- [4]. Siemens / L&T, Contactor Technical Datasheet (45A, 3 Pole, 415V)
- [5]. IS Standards for Electrical Installations and Wiring Practices
- [6]. Basic Electrical Engineering Lab Manual (Diploma Level)
- [7]. H. Cotton, *Electrical Technology*, CBS Publishers
- [8]. L&T Electrical & Automation, MCB Product Catalogue
- [9]. Schneider Electric, Industrial Control Components Handbook
Havells India Ltd., Wiring Devices and Protection Systems Guide
- [10]. IEC Standards on Low Voltage Switchgear and Control gear
- [11]. Polytechnic Lecture Notes on Electrical Installation and Maintenance

BIBLIOGRAPHY

- [12]. www.electrical4u.com – Concepts of contactors and MCBs
- [13]. www.allaboutcircuits.com – Timer and control circuits explanation
- [14]. www.electricaltechnology.org – Three-phase systems and protection devices
- [15]. YouTube tutorials on “Contactor Working and Wiring”
- [16]. Online articles on energy conservation and power management
- [17]. www.electricalnotes.wordpress.com – Practical electrical system explanations
- [18]. www.circuitglobe.com – Concepts of electrical machines and control
- [19]. www.engineeringtoolbox.com – Electrical calculations and data
- [20]. Online PDFs on “Three Phase System and Load Management”