

Simulation of Dc Motor Fed Dc-Dc Converter with High Step-Up Voltage Gain

Charu Sneha Katta¹, Yellaiah Ponnamm²

B.Tech Student, Department of EEE, Sri Indu College of Engineering and Technology, JNTU- Hyd, AP, INDIA
Assistant Professor, Department of EEE, Sri Indu College of Engineering and Technology, JNTU-Hyd, AP, INDIA

Abstract:- This paper presents the simulation DC motor fed using DC-DC converter with high step-up voltage gain. The conventional buck-boost converter has the disadvantage of low voltage gain and has voltage stresses on the switching devices. But in proposed converter by using two inductors with the same level of inductance are charged in parallel during the switch-on period, and are discharged in series during the switch-off period. By using this proposed converter we can achieve high step-up voltage gain without an extremely high duty ratio. The output of the proposed converter is given as input to control the speed of DC motor. This contributes to significant reduction in cost and size while maintaining high conversion efficiency. The simulation of DC motor fed DC-DC converter is carried out on MATLAB /SIMULINK. Simulation results for DC motor fed proposed DC-DC converter are studied

Index Terms:- DC-DC boost converter, High step-up voltage gain, Power stage.

I. INTRODUCTION

Speed control of DC Motor can be achieved by various techniques. This paper is intended to provide a unique solution for low input voltage problems. Theoretically the DC-DC boost converter can achieve a high step up voltage gain with an extremely high duty ratio. However, in practice, the step up voltage gain is limited due to the effect of power switches, rectifier diodes and the equivalent series resistance (ESR) of inductors and capacitors. Also the extremely high duty ratio[5-6] operation will result in serious reverse recovery problem. Many topologies have been presented to provide speed control for a DC motor with low voltage as input. The DC-DC fly back converter[2-9] is a very simple structure with high step up voltage gain and electrical isolation, but the active switch of this converter will suffer high voltage stress due to the leakage inductance and minimizing the voltage stress on the active switch, some energy regeneration techniques have proposed to clamp the voltage stress on the active switch and to recycle the leakage inductance energy. The coupled inductor techniques provide solutions to achieve high voltage gain. Low voltage stresses on active switches, and high efficiency without the penalty of high duty ratio[7]. Some literatures research the transformerless DC-DC converters, which include cascade boost type, the quadratic boost type, the voltage lift type, the capacitor diode voltage multiplier type and the boost type integrating with switched inductor technique[1-3]. The structure of this converter is very simple. Only one power stage is used in this converter. However, this converter has two issues:

- 1) Three power devices exist in the current flow path during the switch on period and two power devices exist in the current flow path during switch of period.
- 2) The voltage stress on active switch equals the output voltage.

A non-magnetic DC-DC high step up converter is proposed in this paper to control speed of a DC motor. Compared with the conventional converter, proposed converter has the following merits:

- 1) Two power devices exist in the current path during switch on period and one power device exists in the current path during switch off period.
- 2) The voltage stresses on the active switches are less than the output voltage.
- 3) Under the same operating conditions, including input voltage, output voltage and output power, the current stress on the active switch of the conventional converter[10]. For getting higher step up voltage gain, the other DC-DC converters are also proposed in this paper. These three proposed DC-DC converters utilize the switched inductor technique, which two inductors with same level of inductance are charged in parallel during the switch-on period and are discharged in series during the switch off period. To achieve high step up voltage gain without the extremely high duty ratio. The operating principles and

steady state analysis are discussed in the following sections. To analyze the steady state characteristics of the proposed converters, some conditions are assumed as:

- 1) All components are ideal. The ON state resistance $R_{DS(ON)}$ of the active switches, the forward voltage drop of the diodes, and the ERS of the inductors and capacitors are ignored
- 2) All capacitors are sufficiently large, and the voltage across the capacitors can be constant.

II. DC MACHINE

Back EMF induced in motor armature. When current passed through the armature of dc machines and its field coils excited torque is established and motor rotates the direction of rotation can be reversed by reversing either armature current or polarity of the magnets. Rotation of the armature gives rise to an induced emf which according to Lenz's law, will oppose the flow of current. Hence if

E_a = the numerical value of the induced emf.
 V_a =the numerical value of the applied voltage
 The armature currents is given by

$$I_a = (V_a - E_a) / r_m$$

$$V_a = E_a + I_a r_m$$

The power input $V_a I_a = E_a I_a + I_a^2 r_m$

The emf generated by the armature must have a perfectly definite value for particular value of the load current

$$E_a = V_a - I_a r_m$$

The induced emf is also determined from ordinary considerations of flux, number of conductors and speed, and its thus

$$E_a = Z_c \times 2p\phi n$$

From above equations are equal we get

$$V_a - I_a r_m = Z_c \times 2p\phi n$$

$$n = \frac{V_a - I_a r_m}{Z_c \times 2P\phi}$$

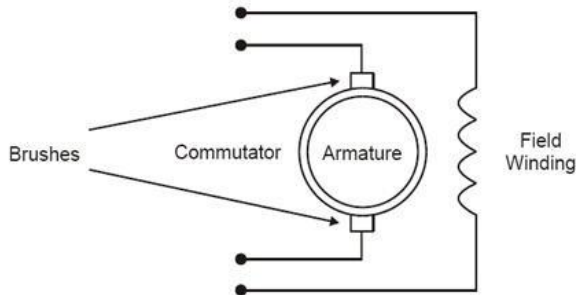

Fig.1 DC motor basic parts

Hence the speed of dc motor may be controlled by

1. Varying the value of the flux.
2. Varying the value of the voltage applied to the motor armature
3. Varying the value of the effective number of conductors in series

Field control: - In field control the applied armature voltage v is maintained constant. Then the speed is represented by equation as

$$\omega_m \propto \frac{1}{f}$$

Armature control: - In this the field current is maintained constant. Then the speed is derived from the equation as

$$w_m = (v - i_a R_a)$$

Hence, varying the applied voltage changes speed. Reversing the applied voltage changes the direction of rotation of the motor

Armature and Field control:- By combination armature and field control for speeds below and above the rated speed, respectively, a wide range of speed control is possible

$$T_e = K \Phi_f i_a$$

Can be normalized if it is divided by rated torque Which is expressed as

$$T_{er} = K \Phi_{fr} i_{ar}$$

$$T_{en} = \frac{T_e}{T_{er}} = K \frac{\Phi_f i_a}{K \Phi_{fr} i_{ar}} = K \Phi_{fn} i_{an} \cdot p.u$$

Normalized eliminates machine constants, compacts the performance equation, and enables the visualization of performance characteristics regardless of machine size on same scale. the normalized torque, flux and armature current are

$$T_{en} = \frac{T_e}{T_{er}} p.u$$

$$\Phi_{fn} = \frac{\Phi_f}{\Phi_{fr}} p.u$$

$$i_{an} = \frac{i_a}{i_{ar}} p.u$$

As the armature current is maintained at 1 p.u

$$T_{en} = \Phi_{fn} \cdot p.u$$

Hence normalized electromagnetic torque characteristics coincides with normalized field flux, similarly the air gap power is,

$$p_{an} = e_n i_{an} \cdot p.u$$

Where e_n is the normalized induced emf.

As i_{an} is set to 1 p.u.,

the normalized air gap power becomes

$$p_{an} = e_n \cdot p.u$$

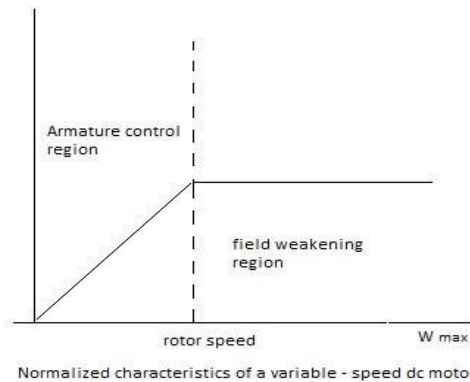

Fig.2 normalized characteristics of variable –speed DC motor.

III. DC MOTOR FED PROPOSED CONVERTER.

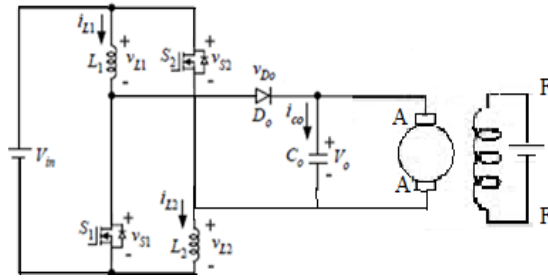

Fig. 3 DC motor fed proposed converter

The Proposed converter , which consists of two active switches ($S1$ and $S2$),two inductors ($L1$ and $L2$) that have the same level of inductance, one output diode D_o , and one output capacitor C_o . Switches $S1$ and $S2$ are controlled simultaneously by using one control signal. Some typical waveforms obtained during continuous conduction mode (CCM) and discontinuous conduction mode (DCM) can be plotted. The operating principles and steady-state analysis of CCM and DCM are presented in details follows

CCM Operation

The operating modes can be divided into two modes ,defined as modes 1 and 2.

Mode 1 [t_0, t_1]:

During this time interval, switches $S1$ and $S2$ are turned on. Inductors $L1$ and $L2$ are charged in parallel from the DC source, and the energy stored in output capacitor C_o is released to the load. Thus, the voltages across $L1$ and $L2$ are given As

$$v_{L1} = v_{L2} = v_{in}$$

Mode 2 [$t1, t2$]:

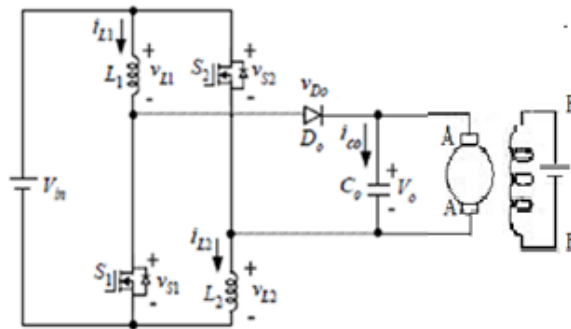

Fig.4 DC motor fed proposed converter in mode-1 operation.

Mode 2 [t_1, t_2]:

During this time interval, $S1$ and $S2$ are turned off. The equivalent circuit is shown in Fig. 4(b). The DC source, $L1$, and $L2$ are series-connected to transfer the energies to C_o and the load. Thus, the voltages across $L1$ and $L2$ are derived as

$$v_{L1} = v_{L2} = \frac{V_{in} - V_o}{2}$$

By using the volt-second balance principle on $L1$ and $L2$, the following equation can be obtained

$$\int_0^{DT_s} v_{in} dt + \int_{DT_s}^{T_s} \frac{v_{in} - v_o}{2} dt = 0$$

Then the voltage gain is given by

$$M_{CCM} = \frac{v_{in}}{v_o} = \frac{1 + D}{1 - D}$$

the voltage stresses on $S1$, $S2$, and D_o are derived as

$$\begin{cases} V_{s1} = V_{s2} = \frac{V_o + V_{in}}{2} \\ V_{D_o} = V_o + V_{in} \end{cases}$$

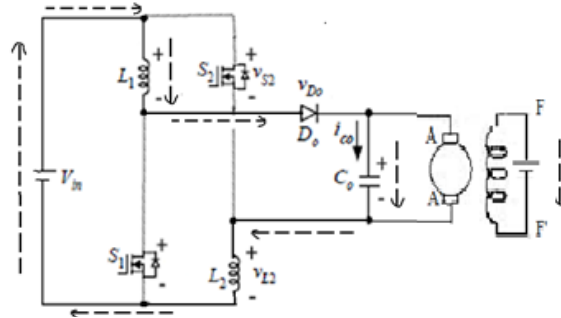

Fig.5 DC motor fed proposed converter in mode-2 operation

DCM Operation

The operating modes can be divided into three modes, defined as modes 1, 2, and 3.

Mode 1 [t0, t1]:

The operating principle is same as that for mode 1 of CCM operation. The two peak currents of L1 and L2 can be found as

$$I_{L1P} = I_{L2P} = \frac{v_{in}}{L}DT_s$$

Where L is the inductance of L1 and L2.

Mode 2 [t1, t2]:

During this time interval, S1 and S2 are turned off. The equivalent circuit is shown in the figure. The DC source, L1, and L2 are series-connected to transfer the energies to Co and the load. Inductor currents iL1 and iL2 are decreased to zero at t = t2. Another expression of IL1p and IL2pis given as

$$I_{L1P} = I_{L2P} = \frac{v_o - v_{in}}{2L}D_2T_s$$

Mode 3 [t2, t3]:

During this time interval, S1 and S2 are still turned off. The energy stored in L1 & L2 is Zero. Thus only the energy stored in Co is discharged to the load. Thus D2 can be derived as follows

$$\text{Thus, only } D_2 = \frac{2Dv_{in}}{v_o - v_{in}}$$

And finally the voltage gain is given by the

$$M_{DCM} = \frac{V_o}{V_{in}} = \frac{1}{2} + \sqrt{\frac{1}{4} + \frac{D^2}{T_L}}$$

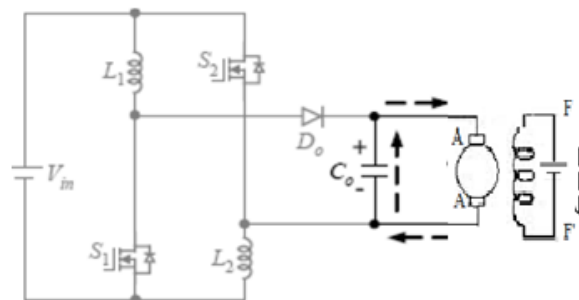

Fig.6 DC motor fed proposed converter in discontinuous conduction mode.

TYPICAL WAVE FORMS OF PROPOSED CONVERTER IN CCM and DCM OPERATION

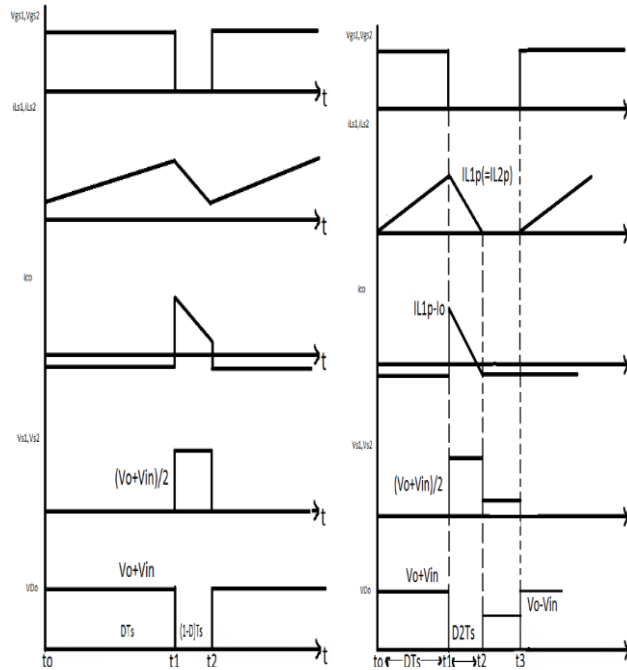
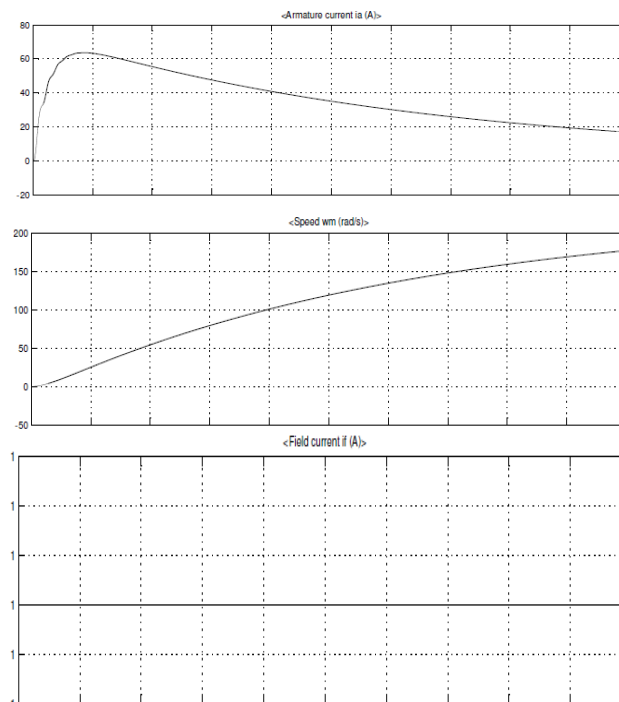

Fig 8. Typical waveforms for proposed converter in CCM and DCM operation.

IV. SIMULATION RESULTS

In order to verify the performance of proposed converter in the application of DC motor, a simulation circuit is designed in MATLAB/SIMULINK. The circuit specifications are $V_{in}=35V$, $V_a=230$ speed $=176\text{rad/sec}$ $L_1=L_2=0.1\text{mH}$. Also, MOSFET NTY100N10 is selected for switches S_1 and S_2 , and the schottky diode MBR20200CT is selected for diode D_0 . Under the above stated conditions, the experimental results are shown in the Fig.9. Also, the input current equals twice the level of the inductor current during the switch-on period, and equals the inductor current during the switch-off period. By this proposed converter the output voltage gain is increased and the voltage stress are also reduced.

In fig.9. the simulation outputs of the armature current (A), speed (rad/sec), field current and electrical torque T_e are shown.



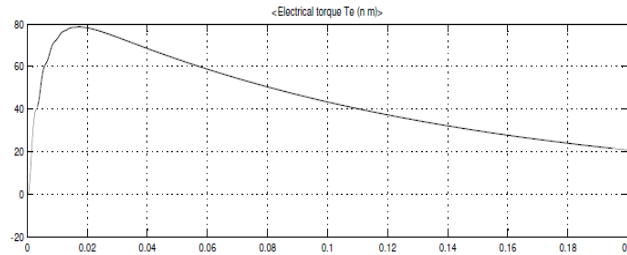

Fig.9 Simulation output waveforms of dc motor fed proposed converter.



V. CONCLUSION

This paper researches a DC motor fed proposed DC-DC converter. The structure of the proposed converter is very simple. As the voltage stresses on the active switches are low, active switches with low voltage rating and low on state resistance levels can be selected. The proposed converter has higher step-up voltage gain than the conventional boost converter. From the simulation results, it is seen that the waveforms agree with the operating principle and steady state analysis. The proposed converter is higher than the conventional.

REFERENCES

- [1]. M. B. Camara, H. Gualous, F. Gustin, A. , and B. Dakyo, "DC/DC converter design for super capacitor and battery power management in hybrid vehicle applications -polynomial control strategy," *IEEE Trans. Ind.Electron.*, vol. 57, no. 2, pp. 587-597, Feb. 2010.
- [2]. T. Bhattacharya, V. S. Giri, K. Mathew, and L. Umanand, "Multiphase bidirectional fly back converter topology for hybrid electric vehicles," *IEEE Trans. Ind. Electron.*, vol. 56, no. 1, pp. 78-84, Jan. 2009.
- [3]. Z. Amjadi and S. S. Williamson, "A novel control technique for a switched-capacitor-converter-based hybrid electric vehicle energy storage system," *IEEE Trans. Ind. Electron.*, vol. 57, no. 3, pp. 926-934, Mar. 2010
- [4]. X. Wu, J. Zhang, X. Ye and Z. Qian, "Analysis and derivations for a family ZVS converter based on a new active clamp ZVS cell," *IEEE Trans. Ind. Electron.*, vol. 55, no. 2, pp. 773-781, Feb. 2008.
- [5]. B. Bryant and M. K. Kazimierczuk, "Voltage-loop power-stage transfer functions with MOSFET delay for boost PWM converter operating in CCM," *IEEE Trans. Ind. Electron.*, vol. 54, no. 1, pp. 347-353, Feb. 2007.
- [6]. D. C. Lu, K. W. Cheng and Y. S. Lee, "A single-switch continuous conduction- mode boost converter with reduced reverse-recovery and switching losses," *IEEE Trans. Ind. Electron.*, vol. 50, no. 4, pp. 767-776, Aug. 2003.
- [7]. N. P. Papanikolaou and E. C. Tatakis, "Active voltage clamp in fly-back converters operating in CCM mode under wide load variation," *IEEE Trans. Ind. Electron.*, vol. 51, no. 3, pp. 632-640, Jun. 2004.
- [8]. B. R. Lin and F. Y. Hsieh, "Soft-switching zeta-fly-back converter with a buck-boost type of active clamp," *IEEE Trans Ind. Electron.*, vol. 54, no. 5, pp. 2813-2822, Oct. 2007.
- [9]. C. M. Wang, "A novel ZCS-PWM flyback converter with a simple ZCSPWM commutation cell," *IEEE Trans. Ind. Electron.*, vol. 55, no. 2, pp.749-757, Feb. 2008.
- [10]. T. F. Wu, Y. S. Lai, J. C. Hung, and Y. M. Chen, "Boost converter with coupled inductors and buck-boost type of active clamp," *IEEE Trans. Ind.Electron.*, vol. 55, no. 1, pp. 154-162, Jan. 2008.

ABOUT AUTHORS

	<p>Charu Sneha Katta , Pursuing B.Tech Pursuing B.Tech degree in Electrical and Electronics Engineering from Sri Indu College of Engineering and Technology (Autonomous),JNTU Hyderabad. Area of interests includes Power Systems, Power Electronics, Control Systems and Renewable Energy Systems.</p>
	<p>Yellaiah.Ponnam , Asst.Professor Received M.Tech degree in Control Systems in Dept. of Electrical and Electronics Engineering, JNTU Hyderabad. He is currently working as Asst.Professor in EEE Department of Sri Indu College of Engineering and Technology (Autonomous) , Hyderabad, His is doing currently research in control system, Power electronics, FACTS and PLCs</p>