

Viability Assessment of Solar PV System for Ihuaba Community in Rivers State

¹ Odums, Wilson, ² Amadi, H. N., ³ Wokoma, B. A.

^{1, 2, 3} Department of Electrical and Electronics Engineering, Faculty of Engineering, Rivers State University, Nigeria

Abstract

This paper seeks on how to supply electricity to Ihuaba community in Rivers State Nigeria, which currently lacks access to grid electricity, thereby limiting healthcare service delivery, constraining educational development, reducing economic productivity and hindering overall socio-economic growth. The absence of stable power supply has forced residents to rely on costly and environmentally harmful alternatives such as diesel generators and kerosene-based systems. In response to these challenges, this study evaluates the technical, economic, and electrical network viability of deploying an off-grid solar photovoltaic (PV) mini-grid system tailored specifically to the energy demand profile of Ihuaba community. A comprehensive field-based load assessment was conducted to determine the community's peak load demand and daily energy consumption requirements. The average daily solar radiation of 3.96 kWh/m²/day obtained from National Aeronautics and Space Administration (NASA) meteorological data was used to estimate the solar energy potential of the location. The system was modeled and analyzed using Renewable Energy Technology Screening Tool (RETScreen) software for energy production estimation, and financial analysis, while Electrical Transient Analyser Programme (ETAP) software was employed to develop a detailed electrical single-line diagram (SLD) and perform load flow, voltage profile, and power loss analyses. The proposed mini-grid system is a 400kW solar PV plant made up of 1288 PV modules of 300W each, a 1900kWh lithium-ion battery energy storage system designed to provide operational stability and autonomy, grid-forming inverters, charge controllers, protection devices, and radial low-voltage feeders. The developed ETAP model accurately represents generation sources, storage units, inverter interfaces, distribution feeders, and load buses, thereby enabling detailed steady-state performance evaluation. Load flow results indicate acceptable voltage regulation within statutory limits and minimal technical losses across the distribution network. Simulation results from RETScreen show that the proposed system can generate approximately 430MWh of electricity annually, sufficient to meet the projected community demand while maintaining operational reliability. Additionally, the system significantly reduces carbon emissions compared to diesel-based generation, thereby contributing to climate change mitigation and environmental sustainability. This study provides a practical and replicable framework for the planning, sizing, and performance evaluation of off-grid renewable energy systems in rural communities across Nigeria and sub-Saharan Africa. The findings align with Nigeria's Renewable Energy Master Plan and Sustainable Development Goal 7 (Affordable and Clean Energy), offering a technically viable and environmentally responsible pathway toward improved energy access, socio-economic development, and long-term community resilience.

Keywords: Electrical Transient Analyser Program, Ihuaba Community, Renewable Energy Technology Software, Solar PV System, Viability Assessment

Date of Submission: 20-03-2026

Date of acceptance: 03-04-2026

I. INTRODUCTION

Nigeria faces persistent electricity challenges, with the national grid unable to meet the demand of its rapidly growing population. The power sector is plagued by inadequate generation, frequent blackouts, high transmission losses, and overdependence on fossil fuels (Akinboro *et al.*, 2016). Rural communities such as Ihuaba in Rivers State have been disproportionately affected, as many of them have never been connected to the grid, leaving households and businesses to rely on costly and polluting alternatives such as diesel and petrol generators. This situation undermines economic activities, hinders access to quality healthcare and education, and lowers the overall standard of living. Uwho *et al.* (2022) emphasize on the need for exploring renewable energy for electricity production in Nigeria in order to optimize the existing energy potential in Nigeria. Renewable energy, particularly solar photovoltaic (PV) technology, has emerged as a viable alternative to bridge the electricity gap in rural Nigeria. Solar energy is abundant, free at the source, and sustainable, as Nigeria receives average daily solar radiation between 3.5–7.0 kWh/m² depending on the region (Cherukupalli, 2018)). In Rivers State, despite its relatively humid climate, sufficient solar resources exist to power homes, schools, health centers, and small

businesses if well harnessed. PV systems convert sunlight directly into electricity, and depending on the design, can be configured as standalone (off-grid), grid-connected, or hybrid systems (Musunuri *et al.*, 2017; Tijani, *et al.*, 2014). Standalone solar PV systems, which are independent of the national grid, are particularly suited for rural electrification projects in Nigeria. These systems consist of solar panels, batteries, inverters, charge controllers, and balance-of-system components, all working together to provide reliable electricity.

Hybrid PV systems, which combine solar power with a backup diesel generator, can also reduce fossil fuel consumption, but their cost and maintenance challenges often make standalone PV more attractive in remote areas. Globally, solar PV has been deployed successfully in rural communities as a cost-effective solution for electrification, leading to improvements in healthcare delivery, agricultural productivity, education, security, and overall socio-economic development (Sedghiyan *et al.*, 2021). However, before adopting PV systems for rural electrification, a viability assessment must be conducted to evaluate technical, economic, and environmental feasibility. For this purpose, RETScreen software, developed by Natural Resources Canada, serves as a valuable tool. RETScreen enables the analysis of renewable energy projects by assessing resource availability (such as solar radiation), system design parameters, energy production, greenhouse gas emission reductions, and financial indicators including net present value (NPV), internal rate of return (IRR), and payback period. This makes it an effective decision-making instrument for governments, private investors, and local communities. Therefore, conducting a viability assessment of a solar PV system for Ihuaba community using RETScreen is essential. It will provide insight into whether solar energy can sustainably meet the community's power demand, highlight the investment requirements, and reveal potential socio-economic benefits. The findings will not only guide electrification of Ihuaba but also serve as a model for similar rural communities in Rivers State and across Nigeria.

Several energy resources exist and are highly abundant based on location. Harnessing these energy resources can be expensive if not optimized. The cost of electricity production could be reduced by optimizing the integrated energy systems according to geographical places. Hence, the optimization of integrated renewable energy systems is a research field with important areas worthy to be investigated Dahlke *et al.* (2018). Prabatha *et al.* (2019) in their work Renewable energy for rural development. The Nigeria perspective conducted an extensive assessment of Nigerian's renewable landscape, focusing on the country's substantial solar energy potential. The research spotlighted that Nigeria receives an average solar radiation of approximately 5.4kWh/m²/day, indicating huge opportunity for utilizing solar energy for electrical generation. Despite this opportunity, the research cited several challenges affecting the widespread adaptation of solar PV systems in Nigeria. And these challenges may include the use of substantial components, inadequate maintenance process, and lack of technical personnel which contributes majorly to the underperformance or failure of PV installations.

Obeng *et al.* (2018) conducted an analysis of a standalone residential solar PV system located in Jos, Nigeria. Their findings revealed that a system comprising ten 275 Wp solar panels, five 100 Ah batteries, a 24/120 A charge controller, and a 2.5 kW inverter could generate approximately 3,132 kWh of electricity annually. From an economic standpoint, the life cycle cost (LCC) was estimated at \$10,111, with an annualized LCC of \$594 and a levelized cost of electricity (LCOE) of \$0.18 per kWh. The study concluded that both the energy output and cost per unit of electricity were suitable for meeting household energy demands. Nevertheless, the study did not assess the environmental benefits of the system or consider potential losses from shading. While existing research mainly concentrated in Northern and Western Nigeria has demonstrated the viability of grid-tied and hybrid PV systems, there remains a lack of evaluation on the feasibility of deploying off-grid PV systems for commercial applications in Nigeria's South-South region, particularly in Port Harcourt.

Nidhi *et al.* (2020) in their work solar engineering of thermal process came up with a comprehensive template for modeling solar radiation and its application in solar energy system design. Their research emphasizes on the relevance of accurate solar radiation data in forecasting the performance of PV systems. They brought out key solar models such as isotropic and anisotropic diffuse radiation models, and precise methods calculating solar angles, which extremely important for optimizing PV panel orientation and tilt angle. The research also highlighted the importance of shading, temperature and other factors affecting the efficiency of the system, rendering practical applications for integrating radiation data into simulation tools like Homer, PVsyst and RETScreen. This research became integral to PV system design enabling detailed energy output forecasting tailored to specific sites. Uwho *et al.* (2022) analyzed the losses and the performance of the PV plant at the Rivers State University which is linked to grid using PVsyst and found that the losses due to modular incompatibility (MisLoss) is 24,705kWh per year, the sum of inverter system loss is 26,294kWh per year while the plant was found 97.7% efficient, saving 9044.009 tons of carbon from being emitted into the atmosphere.

Tijani *et al.* (2014) performed a techno-economic evaluation of an off-grid hybrid PV-diesel-battery system for an international college in Northern Nigeria using HOMER software. They analyzed four configurations: a diesel-only system, a solar PV system with battery storage, and two hybrids PV-diesel systems one with batteries and one without. The cost of electricity for each scenario was found to be \$0.54/kWh for the diesel-only system, \$0.57/kWh for the PV-battery system, \$0.63/kWh for the hybrid without batteries, and \$0.57/kWh for the hybrid with batteries. Based on the analysis, the standalone PV system with battery storage was recommended as the most favorable option due to its reduced emissions and the volatility of diesel fuel prices.

The study also reported annual carbon emissions of 8,477 kg for the PV system, compared to 141,354 kg for the diesel-only system and 14,410 kg for the hybrid setup. Additionally, the optimal PV system was rated at 120 kW, required 972 m² of panel area, and used two batteries (1156 Ah, 12 V).

Farrokhhabadi *et al.* (2020) carried out an extensive life cycle assessment (LCA) of solar PV system highlighting the importance and potential of reducing greenhouse gas (GHG) emissions compared to conventional fossil -based electrical energy generation. The research emphasized that advancement in PV production processes: efficiency optimization and development in region with high solar insolation further improve their environmental benefits. This research reinforces the role of solar PV as an important technology in reducing climate change and achieving better energy goals. Kawabe *et al.* (2020) employed RETScreen software to perform a life cycle cost analysis assessing the feasibility of implementing an off-grid solar PV system in northeastern Nigeria. Their study involved a comparison between the life cycle cost of the off-grid PV system and the cost of electricity from a modern grid. They concluded that the economic viability of such a standalone system was largely influenced by the presence of subsidy programs and the effectiveness of regulatory frameworks. However, the study did not include specific details on the unit cost of the off-grid PV system or its environmental implications. Wallace *et al.* (2018) carried out a comprehensive study to examine the cost effectiveness, finding that declining PV module prices and Government incentive improve the affordability of solar PV projects.

The objectives of this research are to develop a network model of the electricity network in Ihuaba community using ETAP software, access the amount of solar radiation available in Ihuaba in order to determine its sustainability for PV electricity generation; and to design and size an optimal solar photovoltaic (PV) system that meets the assessed electricity demand of Ihuaba community.

II. MATERIALS AND METHOD

2.1 Materials Used

The materials employed in this study consist of computational tools, field measurement instruments, and data resources required for the modelling, simulation, and techno-economic evaluation of a solar photovoltaic (PV) mini-grid system for Ihuaba Community in Ahoada East Local Government Area of Rivers State. The key materials are outlined as follows:

- i. **RETScreen Expert Software:** served as the primary analytical tool for solar resource assessment, energy production modelling, greenhouse gas emissions estimation, and financial viability analysis of the proposed PV system. The software integrates global climate databases such as NASA enabling accurate evaluation of annual solar energy yield, performance ratio, and capacity factor for the study area.
- ii. **Electrical Transient Analyzer Program:** was used for detailed electrical network modelling of the proposed mini-grid. The software provided capabilities for load flow studies, voltage profile analysis, etc. ETAP ensured that the designed system met acceptable power quality standards and operational stability requirements for rural electrification in Ihuaba Community.
- iii. **Meteorological and Solar Resource Data:** Solar irradiance, temperature, and climatic profiles for Ihuaba Community were obtained from the RETScreen climate database powered by NASA and NREL. These datasets were used to determine Global Horizontal Irradiance (GHI), monthly solar availability, and expected PV output performance.
- iv. **Load Data and Field Survey Records:** Primary load data were obtained through household, commercial, institutional, and workshop surveys conducted within Ihuaba Community. The surveys provided detailed information on appliance ratings, usage hours, peak and off-peak load behavior, and aggregated community energy demand. These data formed the basis for daily and annual load modelling and were complemented by spot measurements using digital watt-meters and clamp meters.
- v. **Technical Specifications of System Components:** Manufacturer datasheets for photovoltaic modules, inverters, battery energy storage systems (BESS), charge controllers, and protection devices were used to obtain design and operational characteristics. These specifications included efficiency ratings, temperature coefficients, state-of-charge limits, inverter power ratings, and battery depth-of-discharge parameters required for accurate system modelling.

2.2 Method Used

The method used in this study is Newton Raphson method to determine the steady state condition of the network. RETScreen Expert was utilized for solar resource assessment, energy production modelling, greenhouse gas evaluation, and system performance simulation. The software enables the integration of field-collected load data with global climatic datasets to estimate annual energy yield, capacity factor, and project viability. In addition, Electrical Transient Analyzer Program ETAP software was used to model the distribution network configuration, perform load flow studies, voltage profile evaluation, and assess the stability and reliability of the proposed mini-

grid. The network modelling ensured that the designed PV system meets acceptable electrical standards for voltage regulation, power quality, and protection coordination.

2.2.1 Description of Ihuaba community in Ahoada Rivers State, Nigeria

Ihuaba Community, located in Ahoada East Local Government Area of Rivers State, Nigeria, is a semi-rural settlement within the humid rainforest belt of the Niger Delta, lying approximately 25-30 km northwest of Port Harcourt at coordinates around 5.0°-5.2°N and 6.5°-6.7°E. The single line of the area is shown in Figure 1 while the load Data is in Table 1. The area experiences a tropical monsoon climate with temperatures ranging from 26-32°C, high humidity, and an average solar radiation of 3.96- 4.0 kWh/m²/day, making it suitable for solar photovoltaic applications. With an estimated population of 5,000-7,000 people, Ihuaba’s economy is driven by agriculture, petty trading, fishing, and small-scale workshops such as welding and milling, alongside institutions including schools, churches, and a health center. The community suffers from unreliable or absent grid electricity and relies heavily on petrol generators, kerosene lamps, and diesel-powered machinery, resulting in high energy costs and limited economic growth. Ihuaba was chosen as the study area due to its low electrification level, its diverse mix of residential, commercial, institutional, and productive-use loads, and its strategic relevance to rural electrification initiatives in Rivers State. These characteristics make the community an ideal location for assessing the technical and financial feasibility of a solar PV mini-grid system using RETScreen Expert

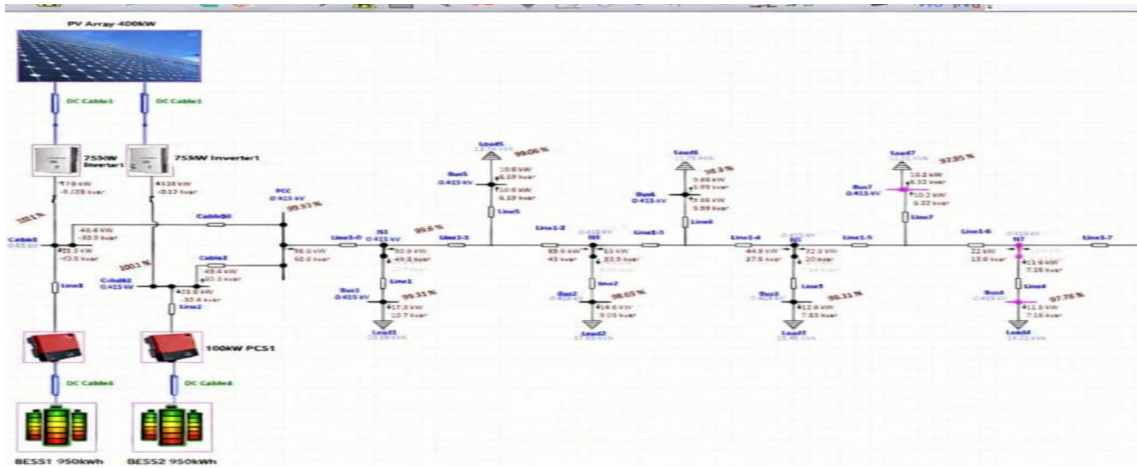

Figure 1 : Single Line Diagram of Ihuaba Community Distribution Network (Source: ETAP)

Table 1: Load Data for Ihuaba 0.415 kV Distribution Network

ID	Rated kV	Rated KVA	Kw	Kvar	Amp
Igbu oshi street	0.415	20.59	17.26	10.7	28.45
Igbu orkwu street	0.415	17.65	14.6	9.05	24.22
Igbu ijeoba street	0.415	15.45	12.64	7.83	21.09
Igbu abuja street	0.415	14.21	11.55	7.16	19.33
Igbu oluko street	0.415	12.74	10.63	6.59	17.56
Igbu eda street	0.415	11.76	9.66	5.99	16.08
Igbu okpu street	0.415	12.51	10.2	6.32	17.05
Igbu ihueni street	0.415	12.74	10.38	6.43	17.35

2.3 Newton-Raphson Power Flow Solution

The Newton-Raphson Power Flow Solution used to determine the steady state condition of the network. Figure 2 shows a 2-bus system which consists of a load fed from a source via a transmission line. For any ith bus.

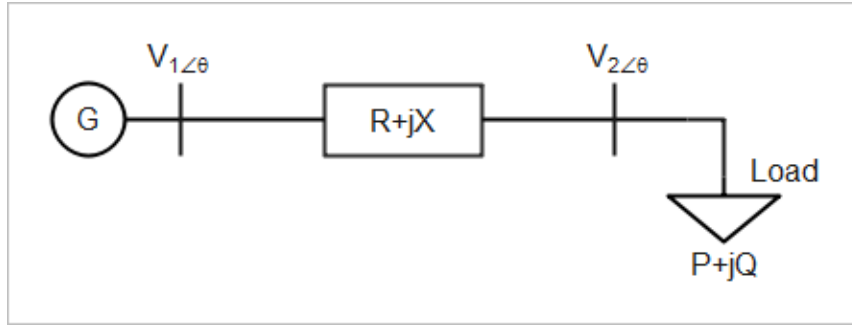

Figure 2: Single Line Diagram of a Two-Bus System

$$\text{Let } V_i = V_i \angle \delta_i \text{ and } V_i^* = V_i \angle -\delta_i, \quad (1)$$

For kth bus,

$$V_k = V_k \angle \delta_k \text{ And } Y_{ik} = Y_{ik} \angle \theta_{ik} \quad (2)$$

The real +and reactive power injected in the network is given by

$$S_i = V_i I_i^* = P_i + jQ_i \quad (3)$$

$$I_i = \left(\frac{S_i}{V_i} \right)^* = \frac{P_i - jQ_i}{V_i^*}$$

$$I_i = \frac{P_i - jQ_i}{V_i^*} = \sum_{k=1}^n Y_{ik} V_k \quad (4)$$

$$P_i - jQ_i = V_i^* \left(\sum_{k=1}^n Y_{ik} V_k \right) \quad (5)$$

$$P_i - jQ_i = V_i^* \left(\sum_{k=1}^n Y_{ik} V_k \angle \delta_k + \theta_{ik} - \delta_i \right) \quad (6)$$

$$P_i - jQ_i = \sum_{k=1}^n |Y_{ik}| |V_i| |V_k| [\cos(\delta_k + \theta_{ik} - \delta_i) + j \sin(\delta_k + \theta_{ik} - \delta_i)] \quad (7)$$

Separating (3.18) into real and imaginary parts we have,

$$P_i = \sum_{k=1}^n |Y_{ik}| |V_i| |V_k| \cos(\delta_k + \theta_{ik} - \delta_i) \quad (8)$$

$$Q_i = -\sum_{k=1}^n |Y_{ik}| |V_i| |V_k| \sin(\delta_k + \theta_{ik} - \delta_i) \quad (9)$$

Where;

Y_{ik} = the admittance matrix

P_i = the injected real power

Q_i = the injected reactive power

δ_i = phase angle

2.4 Assessment of Solar Resource Potential in Ihuaba Community, Ahoada East LGA, Rivers State

To evaluate the feasibility of integrating solar photovoltaic (PV) technology into the proposed energy system for Ihuaba Community, a detailed assessment of the area's solar resource potential is conducted. The community lies within the humid tropical climate zone of the Niger Delta and receives moderate to high solar irradiation throughout the year. This assessment focuses on four key technical indicators: Global Horizontal Irradiance (GHI), Annual Solar Energy Yield, Capacity Factor, and Performance Ratio (PR). These indicators provide a comprehensive understanding of the quantity, stability, and quality of the solar resource available, and collectively determine the suitability of Ihuaba for solar PV deployment.

2.5 Global Horizontal Irradiance (GHI)

GHI represents the total shortwave solar radiation incident on a horizontal surface and is a primary determinant of solar energy availability in any location. It includes both direct and diffuse components of sunlight and is used to characterize the solar potential of a region.

The GHI is expressed mathematically as

$$GHI = DNI \times \cos(\theta_z) + DHI \quad (10)$$

Where;

DNI : direct normal irradiance (W/m^2)

θ_z : solar zenith angle (degrees)

DHI : diffuse horizontal irradiance (W/m^2)

2.5.1 Annual Solar Energy Yield

The Annual Solar Energy Yield (AEY) estimates the total electricity a PV system can generate over a year under local solar conditions as shown in Table 2. It depends on PV module area, conversion efficiency, tilt/orientation, and climatic factors. It can be computed as

$$\text{Daily Energy per panel} = GHI_{avg} \times PV \text{ area} \times \eta \quad (11)$$

$$\text{Annual Energy Yield(AEY)} = \text{Daily Energy per panel} * 365 \quad (12)$$

$$\text{Annual Energy Yield (AEY)} = GHI_{avg} \times PR \times 365 \quad (13)$$

Where;

GHI_{avg} : average daily **global horizontal irradiance** (kWh/m²/day)

PR : performance ratio (typically between 0.75 and 0.85)

η : system efficiency

PV_{area} : PV area for one panel

365: days in a year

Table 2 : Annual Solar Energy Yield Benchmark for Nigeria (kWh/kWp/year) (source: RETScreen)

Expected AEY Range	Solar Potential	Description
< 1,200	Low	Limited feasibility due to cloud cover or shading
1,200 - 1,300	Moderate	Usable with optimized system design
1,300 - 1,600	High	Suitable for rural and commercial,
> 1,600	Very High	Excellent for all PV applications

Ihuaba is expected to fall within the 1,300–1,600 kWh/kWp/year range, indicating good generation potential

2.5.2 Annual energy delivered to the load.

RETScreen uses a solar PV yield model based on solar irradiation, installed capacity, and system performance ratio

$$E_{annual} = P_{rated} \times H_{tilted} \times PR \times Days \quad (14)$$

Where;

E_{annual} = annual electricity delivered to the load (kWh or MWh)

P_{rated} = installed PV Capacity (kW)

H_{tilted} = daily solar radiation on tilted surface (kWh/m²/day)

PR = performance ratio

$Days$ = Number of days in the month.

2.6 Community Energy Profile

A detailed community energy profile was developed for Ihuaba Community to quantify present electricity consumption patterns across residential, commercial, institutional, and productive-use sectors as shown in Tables 3-7. The purpose of this profiling was to establish a reliable baseline load for the RETScreen energy model and to support appropriate sizing of the proposed solar PV mini-grid.

Data collection was conducted through structured household surveys, enumeration of small businesses, interviews with institutional representatives, and direct observation of equipment use. A total of 280 households, 30 shops, various institutions (schools, churches, clinics), and productive-use workshops were included in the field assessment. Additional public services such as water supply pumps, cold storage units, and street lighting were also captured to ensure full representation of community-level demand.

Table 3 : Detailed Household Survey Table

Device (household)	Rating (kW)	Units	Total load	Hours/day	Energy/day (kWh)
LED lighting	0.05	100	5	6	30
Ceiling fans	0.06	50	3	8	24
TV sets	0.06	50	3	6	18
Refrigerators	0.18	20	3.6	16	57.6
Phone charging/small devices	0.01	50	0.5	6	3
Small cookers	1.5	5	7.5	2	15
Household sub total	-	-	22.6	-	147.6

Table 4 : Survey Table for Shops and Small Businesses

Shops/small business	Rating (kW)	Units	Total load	Hours/day	Energy/day (kWh)
Shop lighting	0.2	10	2	12	24
Medium fridges	0.5	6	3	16	48
Heavy equipment	2	3	6	8	48
Workshops	3	2	6	8	48
Small ACs	1.5	2	3	8	24
Shops total	-	-	20	-	192

Table 5 : Survey Table for Institutions (Schools, Churches, Clinics)

Institution	Rating (kW)	Units	Total load	Hours/day	Energy/day (kWh)
Schools	3	2	6	12	72
Churches	2	2	4	10	40
Clinics	1.5	2	3	12	36
Institution sub total	-	-	13	-	148

Table 6 : Survey Table for Community Services

Community service	Rating (kW)	Units	Total load	Hours/day	Energy/day (kWh)
Borehole	3	2	6	12	72
Cold storage	5	1	5	12	60
Telecom equipment	0.5	4	2	24	48
Street/market lighting	0.5	6	3	12	36
Community subtotal	-	-	16	-	216

Table 7 : Survey Table for Workshops (Productive-Use Loads)

Workshops/productive load	Rating (kW)	Units	Total load	Hours/day	Energy/day (kWh)
Welding/fabrication	-	-	5	10	50
Milling	-	-	6	10	60
Dryers	-	-	2	10	20
Workshops subtotal	-	-	13	-	130

Community total energy demand = 833.6kWh/day

Total load = 84.6kW

2.7 Photovoltaic System Modeling

The PV module (Figure 3) consist of a semiconductor which convert light into electricity. The Conversion process is based on photovoltaic effect.

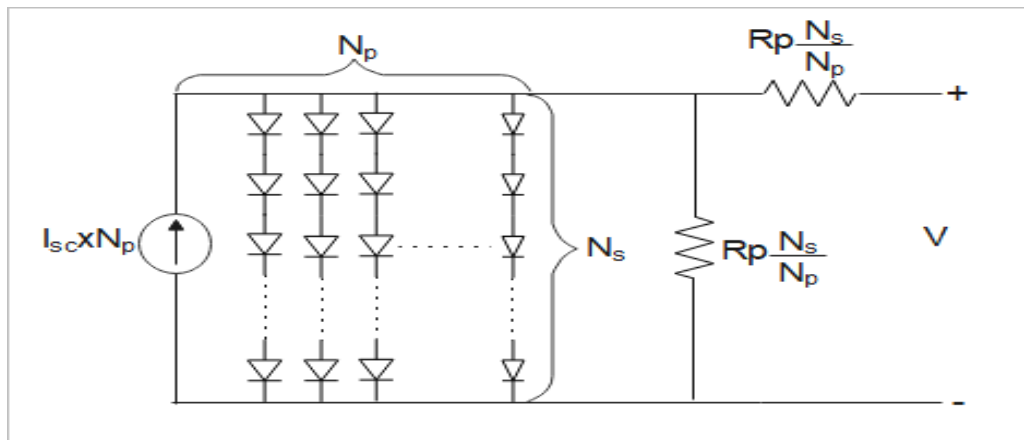

Figure 3 : Model of a Photovoltaic Array

2.7.1 The photo-current (I_L) given by

$$I_L = [I_{SC} + K_i(T - T_r)]G \quad (15)$$

Where;

I_{SC} : short circuit current (A)

K_i : short circuit current at a 25°C and 1kW/m²,

T : operating temperature(K)

T_r : reference temperature =298.15K

G : solar irradiation in kW/m²

3.5.3 Module Reverse Saturation Current (I_{rs}) is given by

$$I_{rs} = \frac{I_{SC}}{\exp\left(\frac{qV_{oc}}{N_s k n T}\right)} - 1 \quad (16)$$

Where;

I_{SC} : short circuit current (A)

q : electron charge, = 1.6 × 10⁻¹⁹ C

V_{oc} : open circuit voltage (V)

N_s : number of cells connected in series;
 n : the ideality factor of the diode
 k : Boltzmann's constant, = 1.3805×10^{-23} J/K.
 2.7.2 Module Saturation Current (I_o) given by

$$I_o = I_{rs} \left(\frac{T}{T_r}\right)^3 \exp\left[\frac{qV_G}{Kn} \left(\frac{1}{T} - \frac{1}{T_r}\right)\right] \quad (17)$$

Where;

I_{rs} : reverse saturation current
 T : operating temperature(K)
 T_r : reference temperature =298.15K
 Q : electron charge ($1.60217646 \times 10^{-19}$ C)
 K : Boltzmann constant ($1.3806503 \times 10^{-23}$ J/K)
 n : the ideality factor of the diode
 VG : band gap energy of the semiconductor

2.7.3 Diode Current (I_d) given by

$$I_d = I_o \left[\exp\left(\frac{qV_d}{KnT}\right) - 1 \right] \quad (18)$$

Where;

I_o : dark saturation current dependent on the cell temperature
 q : electron charge ($1.60217646 \times 10^{-19}$ C)
 K : Boltzmann constant ($1.3806503 \times 10^{-23}$ J/K)
 n : cell idealizing factor
 Vd : diode voltage
 T : operating temperature (K)

2.7.4 Shunt current (I_{sh}) is given by

$$I_{sh} = \frac{\frac{V \cdot N_p}{N_s} + I \cdot R_s}{R_{sh}} \quad (19)$$

Where;

N_s : No of modules in series
 N_p : No of modules in parallel
 I : generated current

2.8 Battery Energy Storage System

Battery energy storage is essential for stabilizing intermittent renewable generation from solar and wind. The battery's state of charge (SOC) changes based on the charging and discharging processes. The change in battery energy

$$SoC(t) = SoC(t - 1) + \frac{\eta_{charge} \times P_{charge}(t) - \frac{P_{discharge}(t)}{\eta_{discharge}}}{E_{bat}} \quad (20)$$

Where;

$SoC(t)$:state of charge at time (t)
 $P_{charge}(t)$: power used to charge the battery (W)
 $P_{discharge}(t)$: power discharged from the battery (W)
 η_{charge} and $\eta_{discharge}$: efficiencies for charging and discharging the battery
 E_{bat} : battery capacity

$$Battery \text{ kWh} = \frac{E_{daily} \times \text{Autonomy days}}{DoD \times \eta} \quad (21)$$

Where:

E_{daily} : daily energy consumed by the load in kilo watt-hours
 Autonomy Days: 2
 DoD: Depth of discharge 80%
 η : Battery efficiency 90%.

III. RESULTS AND DISCUSSION

3.1 Developed Electricity Model of Ihuaba community.

Figure 4 shows the ETAP electricity network model of Ihuaba community, it represents a detailed and structured hybrid solar-battery microgrid designed to operate at 0.415kV within a rural low-voltage distribution. The system integrates a 400kW photovoltaic array interfaced through dual 75kW inverters and two utility-scale 950kWh battery energy storage systems equipped with 200 kW power conversion units, which collectively feed a central AC bus and point of common coupling. From this node, power is distributed through a set of radially

configured feeders supplying dispersed residential and commercial loads, with individual demand levels ranging from approximately 5 to 100 kW. The feeder network maintains voltage profiles within acceptable operational limits reflecting appropriate conductor sizing and balanced DER contribution. Overall, the model provides a robust platform for analyzing microgrid power flow behavior, voltage stability, and DER dispatch strategies, thereby supporting advanced research on renewable energy integration, rural electrification optimization, and resilient micro grid design for developing-region communities

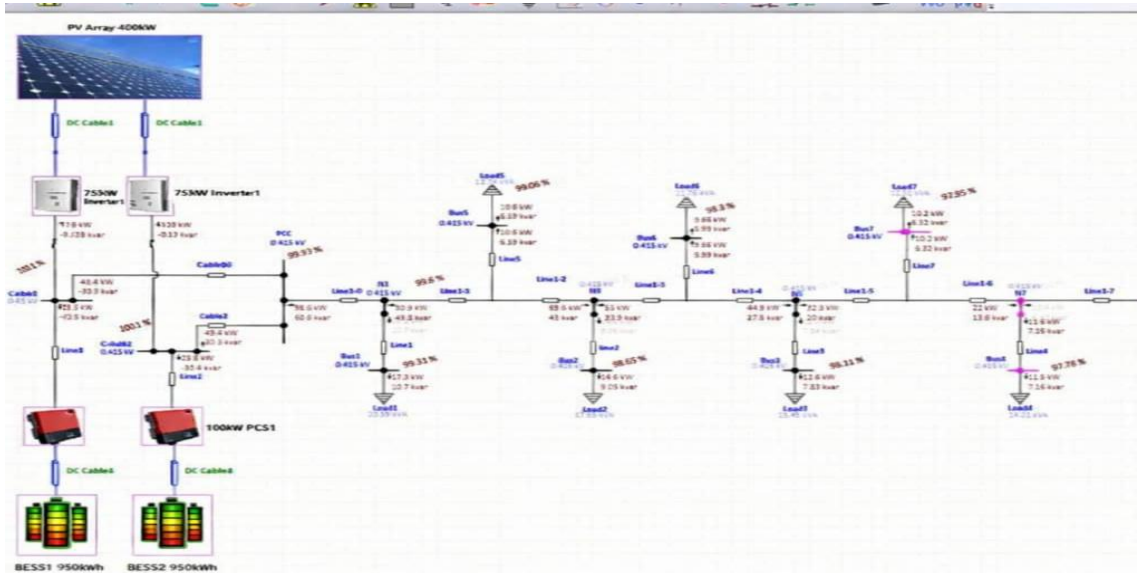

Figure 4 : Steady State Model of Ihuaba Community Network on ETAP Run Mode

Table 8 presents the voltage profile results of the Ihuaba hybrid solar-battery microgrid, showing that all eight buses operate between 97.78% and 99.98% of their nominal 0.415 kV level. The highest voltage is recorded at Bus8 (99.98%), indicating strong voltage support near the upstream AC bus and DER injection point, while the lowest occurs at Bus4 (97.78%), representing a modest 1.53% drop from the network’s maximum value well within acceptable LV distribution limits.

Intermediate buses, such as Bus2 (98.65%) and Bus6 (98.30%), show typical minor reductions corresponding to feeder distance and load concentration. Overall, the narrow voltage spread of only 2.20 percentage points across the entire network confirms that conductor sizing, radial feeder layout, and the combined contributions of the 400kW PV array and 950kWh battery systems effectively maintain stable voltages, supporting reliable operation and validating the microgrid’s suitability for detailed power-flow and rural electrification analyses

Table 8 : Voltage Profile (ETAP)

Bus ID	Nominal kV	Voltage %
Bus1	0.415	99.31
Bus2	0.415	98.65
Bus3	0.415	98.11
Bus4	0.415	97.78
Bus5	0.415	99.06
Bus6	0.415	98.3
Bus7	0.415	97.95
Bus8	0.415	99.98

Table 9 provides a detailed quantitative assessment of branch power flows and associated losses within the Ihuaba hybrid solar-battery micro grid, offering critical insight into the efficiency and electrical performance of the modeled low-voltage distribution network. The results show that the radial feeders collectively transfer approximately 526.38 kW of active power and 278.48 kvar of reactive power, with cumulative real-power losses limited to 1.79 kW and reactive losses to 0.58 kvar. This corresponds to an overall loss level of 1.7922kW of total active power flow, and 0.5768 kvar which is exceptionally low for rural low-voltage networks coordinated to stabilize currents and reduce stress along the feeder.

Table 9 : Branch Flow and Losses (ETAP)

ID	Bus 1	Bus 2	kW Flow	kvar Flow	kW Losses	kvar Losses
Line1-0	N1	PCC	98.6	60.61	0.371	0.119
Line1-1	N2	N1	80.91	49.77	0.378	0.122
Line1-2	N3	N2	69.89	43.06	0.284	0.0915
Line1-3	N4	N3	54.97	33.91	0.266	0.0856
Line1-4	N5	N4	45.03	27.83	0.0801	0.0258
Line1-5	N6	N5	32.28	19.96	0.0723	0.0232
Line1-6	N7	N6	21.99	13.61	0.0385	0.0124
Line1-7	Bus8	N7	10.38	6.43	0.006	0.0019
Line1	Bus1	N1	17.32	10.72	0.0579	0.0186
Line2	N3	Bus2	14.63	9.06	0.0336	0.0108
Line3	N5	Bus3	12.67	7.84	0.0254	0.0082
Line4	N7	Bus4	11.57	7.16	0.0214	0.0069
Line5	N2	Bus5	10.64	6.59	0.0176	0.0057
Line6	N4	Bus6	9.67	5.99	0.0148	0.0048
Line7	N6	Bus7	10.22	6.33	0.0166	0.0053
Line8	Bus21	AC Bus1	25.61	-30.39	0.109	0.0351
					1.7922	0.5768

3.2 Availability of Solar Radiation in Ihuaba Community.

From Table 10, and Figure 5 the daily solar radiation in Port Harcourt is 3.96KWh/m²/day, the monthly solar radiation is 120.38kWh/m²/day and the annual solar radiation is 1444.59kWh/m²/d and it is adequate for power generation. This value is close to the average solar radiation in some cities in Ghana where there are great and existing opportunities for photovoltaic system in rural areas. For instance, the average solar radiation in Tafo, Ghana is 4.02kWh/m²/d. based on the high solar radiation in River's state shown in Fivure 6, there is therefore potential for installation of photovoltaic system for energy supply in Ihuaba community which is a rural area.

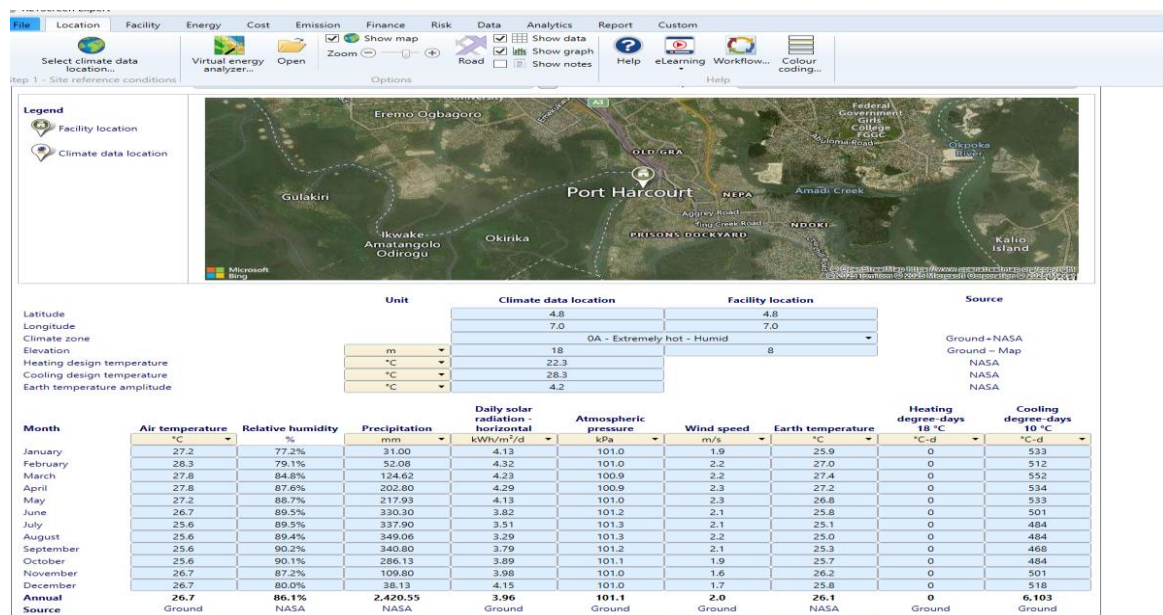

Figure 5 : Average Solar Radiation (source: RETScreen).

Table 10 : Average solar Radiation in Ihuaba Community (Source: RETScreen)

Average daily solar radiation- horizontal (kWh/m ² /d)	Average monthly solar radiation horizontal (kWh/m ² /d)	Average annual solar radiation – horizontal (kWh/m ² /d)
3.96	120.38	1444.59

Figure 6 shows the monthly distribution of solar radiation corresponding to energy potential in Ihuaba community using RETScreen simulation data. The bar chart shows comprehensive seasonal variations that affects the PV system directly. The solar radiation values remain relatively high in the first half of the year, with February (4.32kWh/m²/day) and march (4.23kWh/m²/day) having the highest daily solar irradiation. The months correspond to dry season in Rivers State between June and August, the radiation reduces massively to its lowest levels, with august recording only 3.29kWh/m²/day. This reduction aligns with the peak rainy season, characterized by heavy cloud cover, steady rainfall, and high humidity.

On an annual scale, the average solar radiation is 3.96kWh/m²/day, which is appropriate for PV power generation when compared with internationally accepted thresholds of (≥3.5kWh/m²/day)



Figure 6 : Daily Average Solar Radiation of Ihuaba in Bar Chart, (source: RETScreen)

3.3 Annual Energy Output of the PV System

Figure 7 shows the simulated result of the solar energy availability and the performance of the PV system in Ihuaba community all through the year. The daily solar radiation on a horizontal surface, ranges from 3.29 to 4.32kWh/m²/day, with an annual average of 3.96kWh/m²/day. These values indicate that solar energy is available year-round, though there is fluctuation with seasonal variations, showing lower values during the mid-year months and higher values toward the end and beginning of the year. Also, the tilted surface does not consistently outperform the horizontal surface likely due to suboptimal tilt angles in relation to the sun’s position throughout the year. The electricity delivered to the load by the photovoltaic system also varies monthly, with the lowest delivery in August at 30.33MWh and highest in December at 39.20MWh. These differences align closely with the pattern of solar radiation, emphasizing the systems dependency on solar resource availability. The total annual energy delivered to the load is 429.57MWh, showing the system’s ability to supply a significant amount of clean energy over the year, also, the information or data suggests that while solar energy is a viable option for power generation in Ihuaba community, system performance can be further optimized by adjusting panel orientation to reduce the effects of seasonal fluctuations.

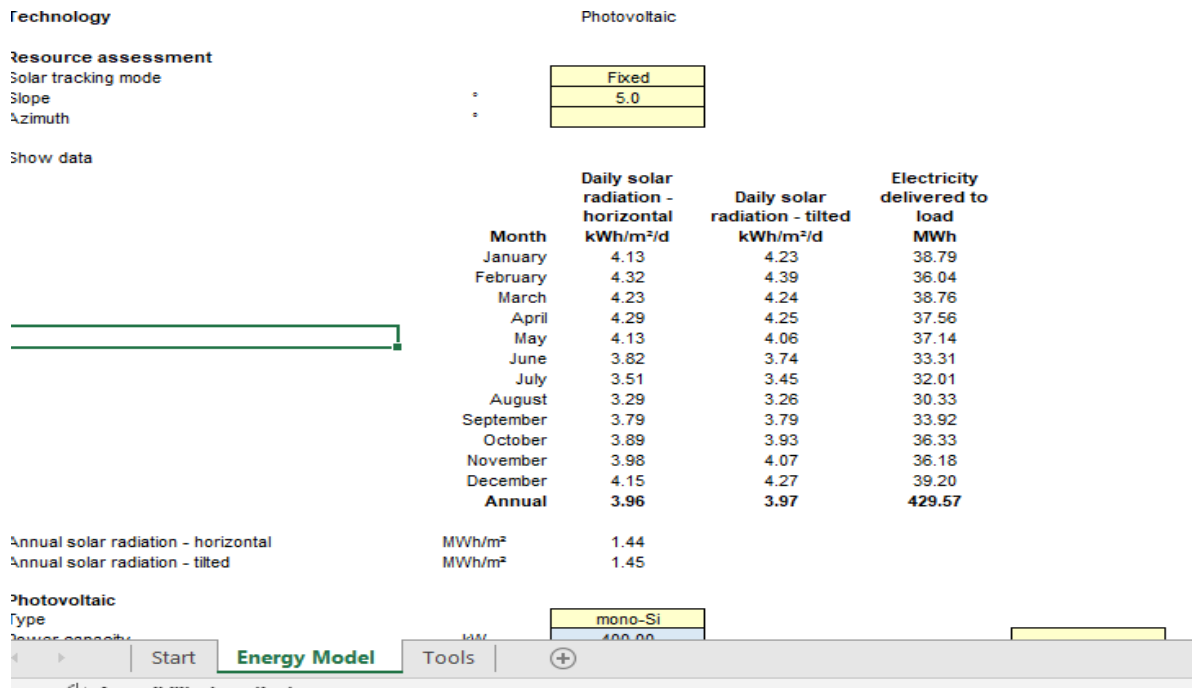

Figure 7 : Annual Electricity Exported to Ihuaba Community (Source: RETScreen)

Figure 8 shows the monthly electricity export results for the 400kW photovoltaic (PV) system and a clear seasonal variation throughout the year. The system generates its highest energy output in December (approximately 39.20MWh), followed closely by January and March, each producing about 39 MWh. Energy production gradually declines from March through August, reaching its lowest value in August at approximately 30.33 MWh. This reduction corresponds to periods of lower solar radiation and increased cloud cover. From September onward, electricity generation begins to rise again, increasing steadily through October and November before peaking in December.

Overall, the PV system produces approximately 430MWh annually, the trend observed in the graph reflects the direct relationship between solar irradiation levels and electricity generation, confirming that seasonal solar resource availability significantly influences the monthly energy output of the system.

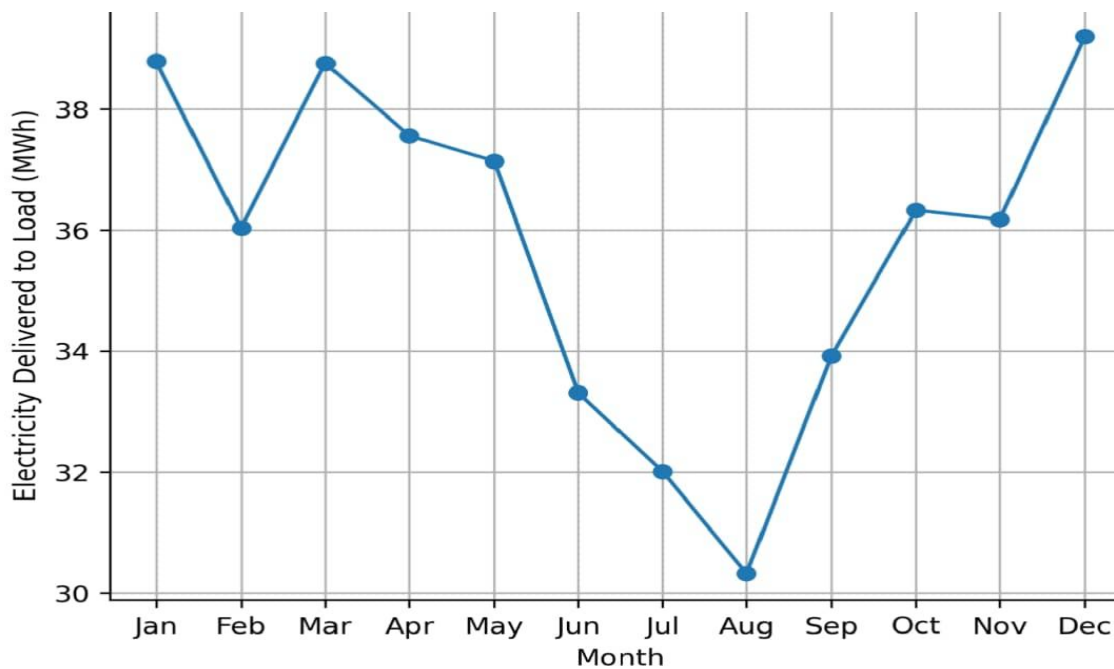

Figure 8 : A Graph of Monthly Electricity Generation of the 400kW Solar PV System (Source: RETScreen)

3.4 Components Design for a 400kW PV System

Table 11 presents the detailed results of the sizing and selection of components for a proposed 400 kW off-grid PV system to meet the energy demand of the Ihuaba community in Rivers State. The system is designed to supply an estimated daily energy demand of 833.6 kWh, ensuring reliable power supply even during periods of low solar radiation or maintenance downtime.

The component sizing was carried out considering factors such as days of autonomy, system voltage, solar radiation data, load requirements, surge currents, and future expansion possibilities. The PV array is oversized at 400 kW, which is four times the base load, to ensure system reliability during periods of low solar irradiance or extended cloudy days. Oversizing the PV array allows the system to meet the energy requirements even under less-than-ideal weather conditions and provides flexibility for future load increases. The configuration consists of 2 modules in series and 644 strings in parallel, resulting in a total of 1,288 PV modules. This configuration ensures high current and low voltage operation, which is compatible with the battery bank and reduces voltage drops across cables, optimal power distribution among strings to maintain balanced system performance, enhanced system reliability, as individual module or string failures will not significantly affect the total energy output, the design also ensures maximum power point tracking (MPPT) efficiency, as each string can be monitored independently, improving overall system efficiency.

The battery bank is designed to store 1900 kWh, sufficient to provide two days of autonomy without sunlight. This ensures continuous power supply during poor weather, solar panel maintenance, or unexpected increases in energy demand.

The battery configuration consists of 4 batteries in series and 42 strings in parallel, for a total of 168 batteries. This configuration provides:

- i. Adequate voltage and current matching with the PV array and inverter.
- ii. Reduced depth of discharge (DoD), prolonging battery life.
- iii. Flexibility to expand the system in the future by adding additional parallel strings without redesigning the series configuration.

The battery bank is designed considering battery efficiency, voltage drop, and charging/discharging rates, ensuring that energy storage and retrieval are optimized.

The total current handling requirement of the system is 8,040 A, distributed across 41 MPPT charge controllers. Each charge controller manages approximately 198 A, ensuring safe and efficient charging of the battery bank. The key benefits of this configuration include:

- i. Optimal power tracking from each PV string to maximize energy extraction.
- ii. Flexibility to replace or service individual controllers without shutting down the entire system.

The use of multiple MPPT controllers ensures system reliability and minimizes energy losses due to mismatched module voltages or shading effects.

The inverter is rated at 150 kW (200 kVA) with a power factor of 0.8, providing sufficient capacity to handle the base load and additional surge loads, such as motor starting currents.

The oversizing of the inverter provides several advantages, like minimizes efficiency losses and heat buildup during operation, ensures reliable operation during short-term load spikes, extends inverter lifespan by reducing the stress on power electronics, accommodates future load expansions, eliminating the need for an immediate replacement when additional demand arises.

The inverter design, combined with the battery bank and PV array, ensures a stable, reliable, and scalable off-grid power system for the Ihuaba community.

Table 11: Results Gotten from the Computation of the Sizes of the Devices Required for the Proposed 400kW off-grid PV System.

Components	Description of Components	Results
Proposed load estimation PV module	Daily energy requirement	833.6kWh/day
	Capacity of module	400kW
	No. of modules in parallel	644
	No. of modules in series	2
	Total modules	1288
Battery bank	Battery bank capacity	1900kWh
	Batteries in parallel	42
	Batteries in series	4
	Total batteries required	168

Charge controller	Charge controller capacity	8040
	Number of controllers	41
Inverter	Rated capacity	150kW(200kVA)

IV. CONCLUSION

This study set out to assess the viability of a solar photovoltaic (PV) system for Ihuaba community using RETScreen software, with specific attention to solar resources, system design, economic feasibility, environmental benefits, and electricity output. The steady state simulation results gotten from ETAP modeling of the proposed solar PV- system for Ihuaba community confirms the technical viability and operational stability of the system. The voltage profile analysis revealed that all the buses within the network operate between 97.78% and 99.98% of the nominal 0.415kV, indicating excellent voltage regulation across the entire distribution network. Notably, the lowest voltage occurred at farthest downstream bus, while the highest voltage was recorded near the point of common coupling (PCC), which is consistent with expected radial feeder behavior in low-voltage distribution systems.

The analysis of the available solar radiation in Ihuaba revealed that the community receives an average daily solar irradiation of 3.96kWh/m²/day which is well above the minimum threshold of 3.5 kWh/m²/day required for sustainable PV electricity generation. This confirms that the location is highly suitable for solar energy deployment. Furthermore, the proposed PV system was projected to deliver 429.57 MWh of electricity annually, which is sufficient to meet the calculated demand of the community and improve energy access in Ihuaba community. Also, based on the community's estimated daily demand of 833.6kWh, a solar PV system configuration was proposed, incorporating the appropriate number of PV modules, batteries, and charge controllers to ensure a reliable off-grid supply. The design demonstrated the technical adequacy of PV technology in meeting the energy demand of Ihuaba.

This research makes the following original and significant contributions to knowledge in the field of rural electrification and renewable energy system design:

- i. This study presents the first documented single-line diagram (SLD) of the electrical distribution network for Ihuaba community. Unlike previous generalized rural electrification studies, the developed SLD captures the actual load distribution, feeder routing, node locations, and electrical interconnections within the community, providing a realistic engineering representation that did not previously exist.
- ii. The research uniquely combines RETScreen-based technical and economic feasibility analysis with ETAP-based electrical network modelling. This integrated approach bridges the gap between high-level feasibility assessments and practical power system design, which is rarely achieved in existing rural electrification literature.
- iii. This work is the first known study to evaluate the solar photovoltaic potential and economic viability of Ihuaba community using RETScreen Expert, incorporating location-specific climate data, real load demand, system sizing, and financial indicators. This establishes a baseline reference for future renewable energy investments in the area.

REFERENCES

- [1]. Akinboro, T., Lu, J. C. V. X., & Guerrero, J. M. (2016). DC microgrids—Part I: A review of control strategies and stabilization techniques. *IEEE Transactions on Power Electronics*, 31(7), 4876–4891. <https://doi.org/10.1109/TPEL.2015.2478857>
- [2]. Cherukupalli, N. (2018). Mokhtari, H., & Blaabjerg, F. (2017). Hierarchical power sharing control in DC microgrids. In *Microgrid* (pp. 63–100). Elsevier. <https://doi.org/10.1016/B978-0-12-803904-8.00003-2>
- [3]. Dahlke, Siavashi, E. M. (2018). PV-STATCOM: A new smart inverter for voltage control in distribution systems. *IEEE Transactions on Sustainable Energy*, 9(4), 1681–1691.
- [4]. Farrokhbadi, M., Cañizares, C. A., Simpson-Porco, J. W., Nasr, E., Fan, L., Mendoza-Araya, P. A., Tonkoski, R., Tamrakar, U., Hatziargyriou, N., Lagos, D., et al. (2020). Microgrid stability definitions, analysis, and examples. *IEEE Transactions on Power Systems*, 35(1), 13–29. [https://doi.org/\[insert DOI\]](https://doi.org/[insert DOI])
- [5]. Kawabe, K., Ota, Y., Yokoyama, A., & Tanaka, K. (2016). Novel dynamic voltage support capability of photovoltaic systems for improvement of short-term voltage stability in power systems. *IEEE Transactions on Power Systems*, 32(3), 1796–1804. <https://doi.org/10.1109/TPWRS.2016.2616439>
- [6]. Musunuri, Zountouridou, E. I., & Hatziargyriou, N. D. (2015). Review of hierarchical control in DC microgrids. *Electric Power Systems Research*, 122, 159–167. [https://doi.org/\[insert DOI\]](https://doi.org/[insert DOI])
- [7]. Nidhi, V., Su, M., Sun, Y., Han, H., & Wang, P. (2020). Feasible power-flow solution analysis of DC microgrids under droop control. *IEEE Transactions on Smart Grid*, 11(3), 2771–2780. [https://doi.org/\[insert DOI\]](https://doi.org/[insert DOI])
- [8]. Obeng, G.Y. & Evers, (2018). Simulation analysis of microgrid voltage stability with multi-induction motor loads. *Electric Power Components and Systems*, 46(5), 560–569. <https://doi.org/10.1080/15325008.2018.1441462>
- [9]. Prabatha, T., Hager, J., Carneiro, B., Hewage, K. & Sadiq, R. (2020). Dynamic voltage support by TL-PV systems to mitigate short-term voltage instability in residential DN. *IEEE Transactions on Power Systems*, 33(5), 4360–4370. <https://doi.org/10.1109/TPWRS.2017.2754406>

- [10]. Sedghiyan, D., Ashouri, A., Maftouni, N., Xiong, Q., Rezaee, E. &Sadeghi, S. (2021). Prioritization of renewable energy resources in five climate zones in Iran using AHP integrated AHP-TOPSIS and AHP-SAW methods. *Sustainable Energy Technologies and Assessments*, 44, 101045. *International Journal of Academic Research*, 2(3) pp. 36-46,
- [11]. Shahzad, M. K., Zahid, A., Rashid, T., Rehan, M. A., Ali, M. & Ahmad, M. (2017), Dynamic voltage support by TL-PV systems to mitigate short-term voltage instability in residential DN. *IEEE Transactions on Power Systems*, 33(5), 4360–4370. <https://doi.org/10.1109/TPWRS.2017.2754406>
- [12]. Tijani, H. O., Tan, C. W. & Umar, N. B. (2014). Techno-economic Analysis of Hybrid Photovoltaic Diesel/Battery off-grid System in Northern Nigeria. *Journal of Renewable and Sustainable Energy, Energy* 6(3), DOI : 10.1063/1.4873122
- [13]. Uwho, K. O., Amadi, H. O. & Ahiakwo, C. O. (2022). Loss, Performance and Carbon Analysis of the Grid-connected PV System, Rivers State University using PVsyst. *Recent Trends in Control and Converter*, 5(3), 1-10
- [14]. Uwho, K. O., Idoniboyeobu, D. C. & Amadi, H. N. (2022). Design and Simulation of 500kW Grid-connected PV System for Faculty of Engineering, Rivers State University using PVsyst Software. *Iconic Research and Engineering Journals*, 5(8), 221-229
- [15]. Wallace, W. L., Jingming, L. &Shangbin, G. (2022). Review on control of DC microgrids and multiple microgrid clusters. *IEEE Journal of Emerging and Selected Topics in Power Electronics*, 5(3), 928–948. <https://doi.org/10.1109/JESTPE.2017.2651114>